

# Electrical Documentation

## File 1: General Diagrams and Descriptions and Circuit Diagrams

---

### Contents:

- 1.6 Circuit Diagrams
  - Singel line diagram
  - Installation Diagram
  - Cable list
  - Layouts



## Schade Lagertechnik GmbH

Project description	Tripper car 523 TR 01 Tonasa		
Project	20.230		
Job number	28/04/2010		
Commission	12345		
Manufacturer (company)	Schade Lagertechnik GmbH Dorstener Straße 360 44653 Herne	Manufacturing date	2010
		Enclosures	RITTAL TS 8 series
		Control voltage	220V AC / 24V DC
		Power supply	380 V AC
		Regulation	DIN VDE 0100/DIN EN 60439-1
Responsible for project	Herr Dauterstedt		
Eplan	Frau Schmidt		
Created on	15.07.2010		
Edit date	18.10.2010		
			Number of pages 116

		Date	20.10.2010	Tripper car 523 TR 01 Tonasa		Title page/cover sheet	20.230	= 523TR01
		Ed.	Schmidt				28/04/2010	+ GEN
		Appr	Dauterstedt				12345	Page 1 of 11
Modification	Date	Name	Original	Replacement of	Replaced by			001

# Table of contents

Column X: An automatically generated page was edited

F06\_001

Page	Page description	supplementary page field	Date	Edited by	X
=523TR01+GEN/1	Title page/cover sheet	001	01.10.2010	Schmidt	X
=523TR01+GEN/2	Table of contents : =523TR01+GEN/1 - =523TR01+MC1.05/5	002	18.10.2010	Schmidt	
=523TR01+GEN/2.a	Table of contents : =523TR01+MC1.05/6 - =523TR01+CABLE/7	003	18.10.2010	Schmidt	
=523TR01+GEN/2.b	Table of contents : =523TR01+CABLE/8 - =523TR01+Clamps/5	004	18.10.2010	Schmidt	
=523TR01+GEN/2.c	Table of contents : =523TR01+Clamps/6 - =523TR01+Clamps/20	005	18.10.2010	Schmidt	
=523TR01+GEN/7	Designation	006	01.10.2010	Schmidt	
=523TR01+GEN/8	Designation	007	01.10.2010	Schmidt	
=523TR01+GEN/10	Structure identifier overview	008	01.10.2010	Schmidt	
=523TR01+GEN/11	Project information	009	18.10.2010	Schmidt	
=523TR01+LAY/1	Layout DS01	010	01.10.2010	Schmidt	
=523TR01+LAY/2	Layout MC1	011	01.10.2010	Schmidt	
=523TR01+LAY/3	Layout MC1	012	01.10.2010	Schmidt	
=523TR01+SIN/1	Single line	013	01.10.2010	Schmidt	
=523TR01+SIN/2	Single line	014	01.10.2010	Schmidt	
=523TR01+SIN/3	Single line	015	01.10.2010	Schmidt	
=523TR01+MC1.01/1	Power supply	016	01.10.2010	Schmidt	
=523TR01+MC1.01/2	Power supply	017	01.10.2010	Schmidt	
=523TR01+MC1.01/3	Main power switch	018	01.10.2010	Schmidt	
=523TR01+MC1.01/4	Main power switch	019	01.10.2010	Schmidt	
=523TR01+MC1.01/5	Digital input/ output	020	01.10.2010	Schmidt	
=523TR01+MC1.02/1	Control voltage 220V AC	021	01.10.2010	Schmidt	
=523TR01+MC1.02/2	Control voltage 220V AC	022	01.10.2010	Schmidt	
=523TR01+MC1.02/3	Control voltage 24V DC	023	01.10.2010	Schmidt	
=523TR01+MC1.02/4	Digital inputs / outputs	024	01.10.2010	Schmidt	
=523TR01+MC1.03/1	Lighting transformer	025	01.10.2010	Schmidt	
=523TR01+MC1.03/2	Lighting circuit	026	01.10.2010	Schmidt	
=523TR01+MC1.04/1	Lighting circuit I	027	01.10.2010	Schmidt	
=523TR01+MC1.04/2	Panel lights, heater and cooler	028	01.10.2010	Schmidt	
=523TR01+MC1.05/1	Basic-Rack	029	01.10.2010	Schmidt	
=523TR01+MC1.05/2	ET200S	030	01.10.2010	Schmidt	
=523TR01+MC1.05/3	ET200S	031	01.10.2010	Schmidt	
=523TR01+MC1.05/4	ET200S	032	01.10.2010	Schmidt	
=523TR01+MC1.05/5	ET200S	033	01.10.2010	Schmidt	

1

2.a

			Date	20.10.2010	Tripper car 523 TR 01 Tonasa		Table of contents : =523TR01+GEN/1 - =523TR01+MC1.05/5		20.230	= 523TR01
			Ed.	Schmidt					28/04/2010	+ GEN
			Appr	Dauterstedt					12345	Page 2 of 11
Modification	Date	Name	Original		Replacement of	Replaced by				002

# Table of contents

Column X: An automatically generated page was edited

F06\_001

Page	Page description	supplementary page field	Date	Edited by	X
=523TR01+MC1.05/6	ET200S	034	01.10.2010	Schmidt	
=523TR01+MC1.06/1	Wlan	035	01.10.2010	Schmidt	
=523TR01+MC1.09/1	EMERGENCY STOP safety switching device	036	01.10.2010	Schmidt	
=523TR01+MC1.09/2	Emergency stop switch	037	01.10.2010	Schmidt	
=523TR01+MC1.09/3	Emergency stop switch	038	01.10.2010	Schmidt	
=523TR01+MC1.09/4	Emergency stop switch	039	01.10.2010	Schmidt	
=523TR01+MC1.09/5	Emergency stop signals	040	01.10.2010	Schmidt	
=523TR01+MC1.09/6	Digital inputs / outputs	041	01.10.2010	Schmidt	
=523TR01+MC1.09/7	Digital inputs / outputs	042	01.10.2010	Schmidt	
=523TR01+MC1.17/1	Tripper belt conveyor 523BC02	043	01.10.2010	Schmidt	
=523TR01+MC1.17/2	Tripper belt conveyor 523BC02	044	01.10.2010	Schmidt	
=523TR01+MC1.20/1	Travel drive	045	18.10.2010	Schmidt	
=523TR01+MC1.20/2	Travel drive	046	01.10.2010	Schmidt	
=523TR01+MC1.20/3	Travel drive	047	01.10.2010	Schmidt	
=523TR01+MC1.20/4	Travel drive	048	01.10.2010	Schmidt	
=523TR01+MC1.20/5	Travel drive	049	01.10.2010	Schmidt	
=523TR01+MC1.20/6	Travel drive	050	01.10.2010	Schmidt	
=523TR01+MC1.20/7	Travel drive	051	01.10.2010	Schmidt	
=523TR01+MC1.20/8	Travel drive	052	01.10.2010	Schmidt	
=523TR01+MC1.20/9	Travel drive	053	01.10.2010	Schmidt	
=523TR01+MC1.20/10	Travel drive	054	18.10.2010	Schmidt	
=523TR01+MC1.20/11	Travel drive	055	18.10.2010	Schmidt	
=523TR01+STKL/1	Parts list : SIE.3TX4701-0AN1 - SIE.5SY6110-6	056	18.10.2010	Schmidt	X
=523TR01+STKL/1.a	Parts list : SIE.5SY6116-6 - SIE.3SB3245-0AA41	057	18.10.2010	Schmidt	X
=523TR01+STKL/1.b	Parts list : SIE.3SB3246-0AA21 - SIE.6XV1875-5CH10	058	18.10.2010	Schmidt	X
=523TR01+STKL/1.c	Parts list : SIE.6XV1875-2A235M - SIE.6SE6400-4BD16-5CA0	059	18.10.2010	Schmidt	X
=523TR01+CABLE/1	Cable overview : LT1PO1 - W37	060	18.10.2010	Schmidt	
=523TR01+CABLE/2	Cable diagram LT1PO1	061	18.10.2010	Schmidt	
=523TR01+CABLE/3	Cable diagram MC1PO1	062	18.10.2010	Schmidt	
=523TR01+CABLE/4	Cable diagram MC1PO2	063	18.10.2010	Schmidt	
=523TR01+CABLE/5	Cable diagram MO1CO1	064	18.10.2010	Schmidt	
=523TR01+CABLE/6	Cable diagram MO1PO1		18.10.2010	Schmidt	
=523TR01+CABLE/7	Cable diagram MO2CO1		18.10.2010	Schmidt	

			Date	20.10.2010	Tripper car 523 TR 01 Tonasa		Table of contents : =523TR01+MC1.05/6 - =523TR01+CABLE/7	20.230	= 523TR01
		Ed.	Schmidt	28/04/2010				+ GEN	
		Appr	Dauterstedt	12345				Page 2.a of 11	
Modification	Date	Name	Original	Replacement of	Replaced by				003

# Table of contents

Column X: An automatically generated page was edited

F06\_001

Page	Page description	supplementary page field	Date	Edited by	X
=523TR01+CABLE/8	Cable diagram MO2PO1		18.10.2010	Schmidt	
=523TR01+CABLE/9	Cable diagram W3		18.10.2010	Schmidt	
=523TR01+CABLE/10	Cable diagram W4		18.10.2010	Schmidt	
=523TR01+CABLE/11	Cable diagram W5		18.10.2010	Schmidt	
=523TR01+CABLE/12	Cable diagram W6		18.10.2010	Schmidt	
=523TR01+CABLE/13	Cable diagram W7		18.10.2010	Schmidt	
=523TR01+CABLE/14	Cable diagram W8		18.10.2010	Schmidt	
=523TR01+CABLE/15	Cable diagram W9		18.10.2010	Schmidt	
=523TR01+CABLE/16	Cable diagram W10		18.10.2010	Schmidt	
=523TR01+CABLE/17	Cable diagram W11		18.10.2010	Schmidt	
=523TR01+CABLE/18	Cable diagram W12		18.10.2010	Schmidt	
=523TR01+CABLE/19	Cable diagram W13		18.10.2010	Schmidt	
=523TR01+CABLE/20	Cable diagram W14		18.10.2010	Schmidt	
=523TR01+CABLE/21	Cable diagram W15		18.10.2010	Schmidt	
=523TR01+CABLE/22	Cable diagram W16		18.10.2010	Schmidt	
=523TR01+CABLE/23	Cable diagram W17		18.10.2010	Schmidt	
=523TR01+CABLE/24	Cable diagram W18		18.10.2010	Schmidt	
=523TR01+CABLE/25	Cable diagram W19		18.10.2010	Schmidt	
=523TR01+CABLE/26	Cable diagram W25		18.10.2010	Schmidt	
=523TR01+CABLE/27	Cable diagram W26		18.10.2010	Schmidt	
=523TR01+CABLE/28	Cable diagram W27		18.10.2010	Schmidt	
=523TR01+CABLE/29	Cable diagram W28		18.10.2010	Schmidt	
=523TR01+CABLE/30	Cable diagram W29		18.10.2010	Schmidt	
=523TR01+CABLE/31	Cable diagram W30		18.10.2010	Schmidt	
=523TR01+CABLE/32	Cable diagram W34		18.10.2010	Schmidt	
=523TR01+CABLE/33	Cable diagram W35		18.10.2010	Schmidt	
=523TR01+CABLE/34	Cable diagram W36		18.10.2010	Schmidt	
=523TR01+CABLE/35	Cable diagram W37		18.10.2010	Schmidt	
=523TR01+Clamps/1	Terminal diagram =523TR01+MC1.01-X01	097	18.10.2010	Schmidt	
=523TR01+Clamps/2	Terminal diagram =523TR01+MC1.01-X02	098	18.10.2010	Schmidt	
=523TR01+Clamps/3	Terminal diagram =523TR01+MC1.02-X03	099	18.10.2010	Schmidt	
=523TR01+Clamps/4	Terminal diagram =523TR01+MC1.02-X03.1	100	18.10.2010	Schmidt	
=523TR01+Clamps/5	Terminal diagram =523TR01+MC1.02-X05	101	18.10.2010	Schmidt	

Z.a

Z.c











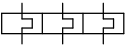









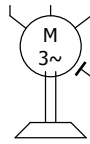
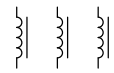











			Date	20.10.2010	Tripper car 523 TR 01 Tonasa		Table of contents : =523TR01+CABLE/8 - =523TR01+Clamps/5		20.230	= 523TR01
			Ed.	Schmidt					28/04/2010	+ GEN
			Appr	Dauterstedt					12345	Page 2.b of 11
Modification	Date	Name	Original		Replacement of	Replaced by				004

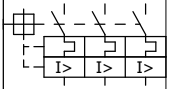







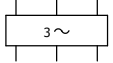

# Table of contents

Column X: An automatically generated page was edited

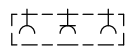
F06\_001

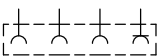
Page	Page description	supplementary page field	Date	Edited by	X
=523TR01+Clamps/6	Terminal diagram =523TR01+MC1.02-XT01	102	18.10.2010	Schmidt	
=523TR01+Clamps/7	Terminal diagram =523TR01+MC1.02-XT03	103	18.10.2010	Schmidt	
=523TR01+Clamps/8	Terminal diagram =523TR01+MC1.03-X01	104	18.10.2010	Schmidt	
=523TR01+Clamps/8.a	Terminal diagram =523TR01+MC1.03-X01	105	18.10.2010	Schmidt	
=523TR01+Clamps/9	Terminal diagram =523TR01+MC1.04-X01	106	18.10.2010	Schmidt	
=523TR01+Clamps/10	Terminal diagram =523TR01+MC1.06-X03.1	107	18.10.2010	Schmidt	
=523TR01+Clamps/11	Terminal diagram =523TR01+MC1.09-X03.1	108	18.10.2010	Schmidt	
=523TR01+Clamps/11.a	Terminal diagram =523TR01+MC1.09-X03.1	109	18.10.2010	Schmidt	
=523TR01+Clamps/12	Terminal diagram =523TR01+MC1.09-X05	110	18.10.2010	Schmidt	
=523TR01+Clamps/13	Terminal diagram =523TR01+MC1.17-X03	111	18.10.2010	Schmidt	
=523TR01+Clamps/14	Terminal diagram =523TR01+MC1.20-X01	112	18.10.2010	Schmidt	
=523TR01+Clamps/15	Terminal diagram =523TR01+MC1.20-X03 =523TR01+MC1.20-X03	113	18.10.2010	Schmidt	
=523TR01+Clamps/16	Terminal diagram =523TR01+MC1.20-X05	114	18.10.2010	Schmidt	
=523TR01+Clamps/17	Terminal diagram =523TR01+MC1.20-X06	115	18.10.2010	Schmidt	
=523TR01+Clamps/18	Terminal diagram =523TR01+DS1-X	116	18.10.2010	Schmidt	
=523TR01+Clamps/19	Terminal diagram =523TR01+JB.20-X03	117	18.10.2010	Schmidt	
=523TR01+Clamps/20	Terminal diagram =523TR01+CLIENT-X	118	18.10.2010	Schmidt	

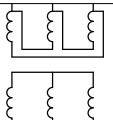
sign	designation	note	sign	designation	note	sign	designation	note	sign	designation	note
	B	overload relay		E	heater		M	motor		Q	contactor
	B	level switch NO		F	circuit breaker 1-pole		M	duble winding motor		Q	main contact
	B	level switch NC		F	circuit breaker 3-pole		M	motor brake		R	coil
	B	termistor		K	relay		P	counter		R	resistor
	B	initiator		K	contact NO		P	Amperemeter		R	diode
	E	hooter		K	contact NC		P	Voltmeter		S	Emergency-stop push button
	E	lighting		K	contact NC delay		Q	circuit breaker		S	push button NO
	E	lamp		K	contact CO		Q	undervoltage coil (inside circuit breaker)		S	push button NC
	E	flashlight		K	valve		S	key operated switch NO			

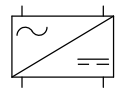
sign	designation	note	sign	designation	note	sign	designation	note	sign	designation	note
	S	key operated switch NC		V	sinus-filter						
	S	selector switch NO		X	terminal						
	S	selector switch NC		X	socket 1-pole						
	S	end switch NO		X	socket 3-pole						
	S	end switch NC									
		transformer 2-pole									
	T	transformer 3-pole									
	T	current transformer									
	T	power supply									

- GEN General information
- SIN Single Line Diagram
- LAY Layout
- 01 Main Power Supply
- 02 Control Supply
- 03 Lighting
- 04 HVAC (Heating, Ventilation, Aircondition)
- 05 PLC
- 06 Interface
- 09 Safety Devices
- 20 Travel drive

			Date	20.10.2010	Tripper car 523 TR 01 Tonasa		Structure identifier overview	20.230	= 523TR01
			Ed.	Schmidt				28/04/2010	+ GEN
			Appr	Dauterstedt				12345	Page 10 of 11
Modification	Date	Name	Original		Replacement of	Replaced by			008

Designation	voltage	Color	Terminal strip
Main power supply	380V AC	orange or	-X00
Main power circuit	380V AC /220V AC	black bk	-X01
Transformer circuit		withe wh	-X02
Control voltage	220V AC	red rd	-X03
Control voltage	220V AC	red rd	-X03.1 Under voltage even when the main switch triggered
Control voltage	220V DC	brown bn	-X04
Control voltage	24V DC	blue bu	-X05
Analog signals		withe wh	-X06
Floating contacts		orange or	-X07
Neutral conductor		blue bu	
Protective ground		green/yellow gn/ye	

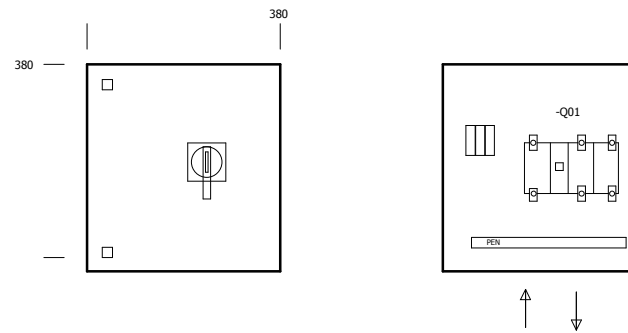

+GEN/11

			Date	20.10.2010	Tripper car 523 TR 01 Tonasa		Layout DS01	20.230	= 523TR01
			Ed.	Schmidt				28/04/2010	+ LAY
			Appr	Dauterstedt				12345	Page 1 of 3
Modification	Date	Name	Original		Replacement of	Replaced by			010

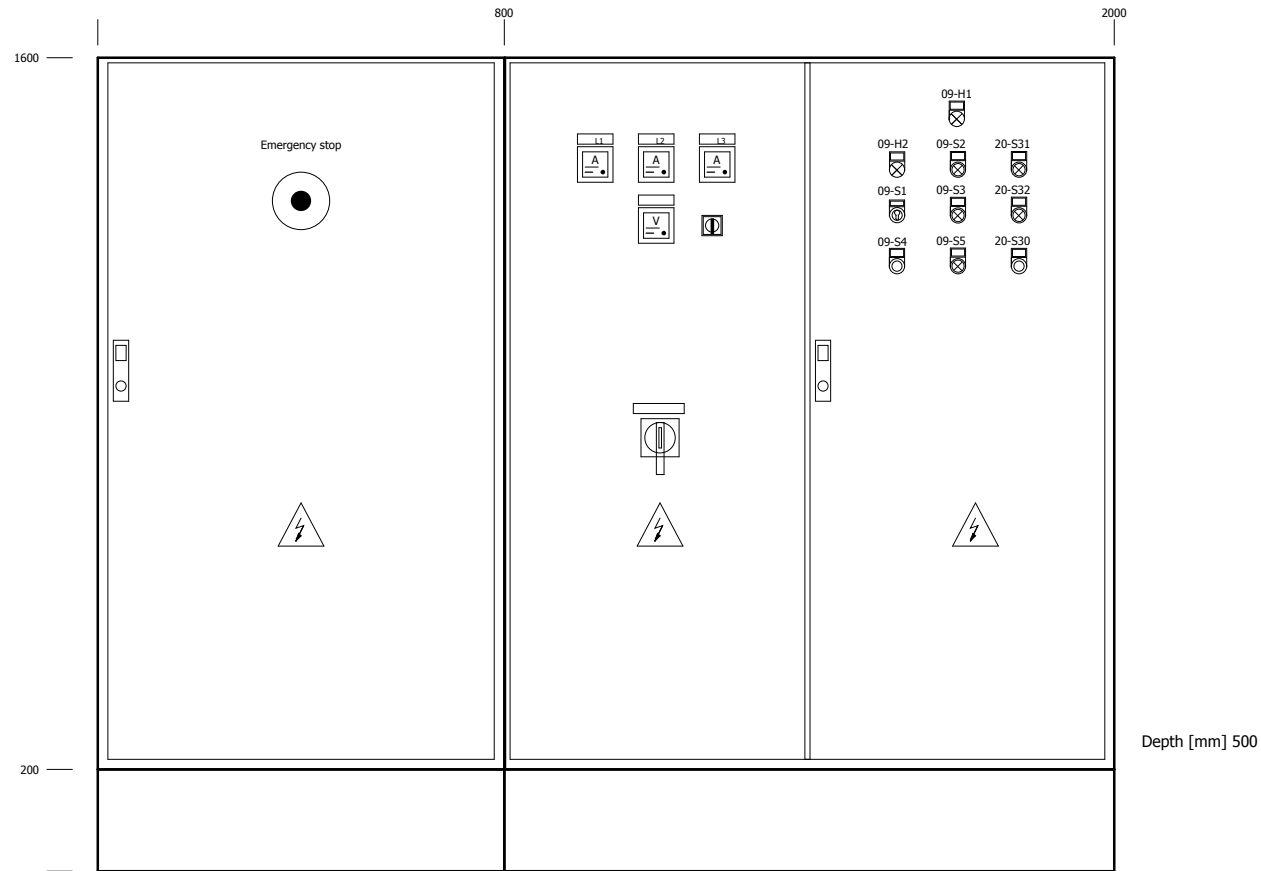

transport unit

09-H1 Centralized fault indication

- 09-H2 Automatic ON
- 09-S1 Manual-Auto
- 09-S4 Lamptest
- 09-S2 Control ON
- 09-S3 Control OFF
- 09-S5 Reset
- 20-S31 Travel drive right ON
- 20-S32 Travel drive left ON
- 20-S30 Travel drive OFF

			Date	20.10.2010	Tripper car 523 TR 01 Tonasa		Layout MC1	20.230	= 523TR01
			Ed.	Schmidt				28/04/2010	+ LAY
			Appr	Dauterstedt				12345	Page 2 of 3
Modification	Date	Name	Original	Replacement of	Replaced by				011

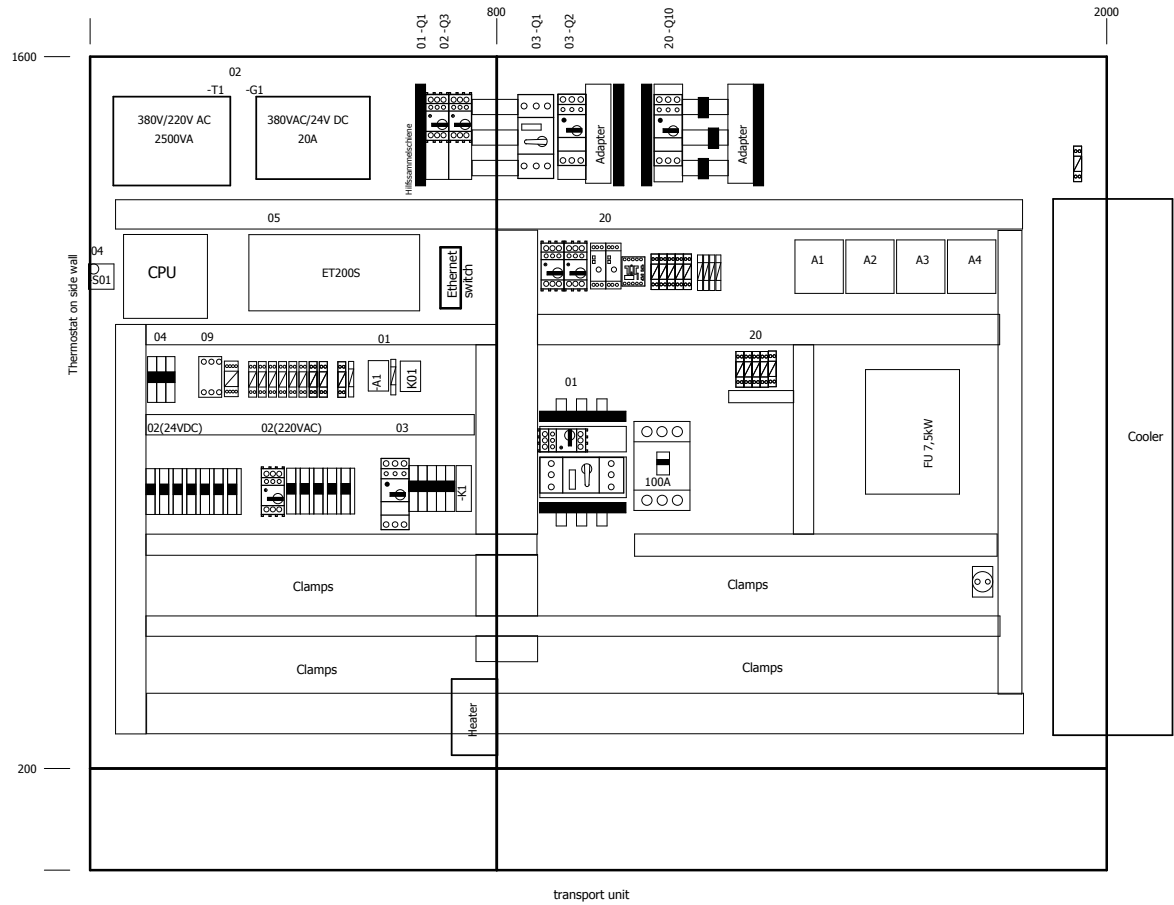

Date	20.10.2010
Ed.	Schmidt
Appr	Dauterstedt
Modification	Date
Name	Original

Tripper car 523 TR 01	
Tonasa	
Replacement of	Replaced by



Layout MC1
------------

20.230	= 523TR01
28/04/2010	+ LAY
12345	Page 3 of 3
	012

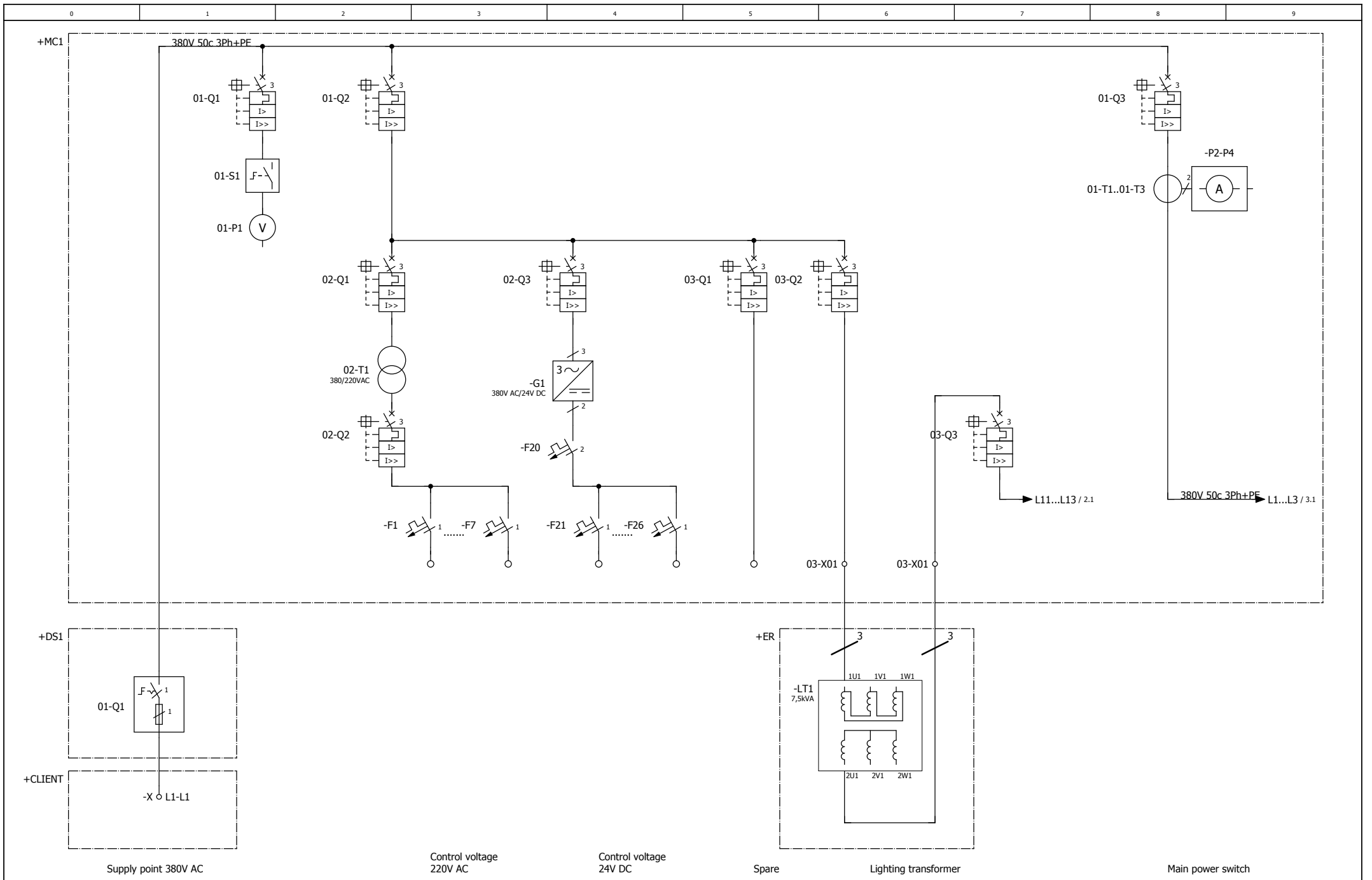

+LAY/3

Date	20.10.2010
Ed.	Schmidt
Appr	Dauterstedt
Original	

Tripper car 523 TR 01	
Tonasa	
Replacement of	Replaced by



Single line

20.230	= 523TR01
28/04/2010	+ SIN
12345	Page 1 of 3
	013

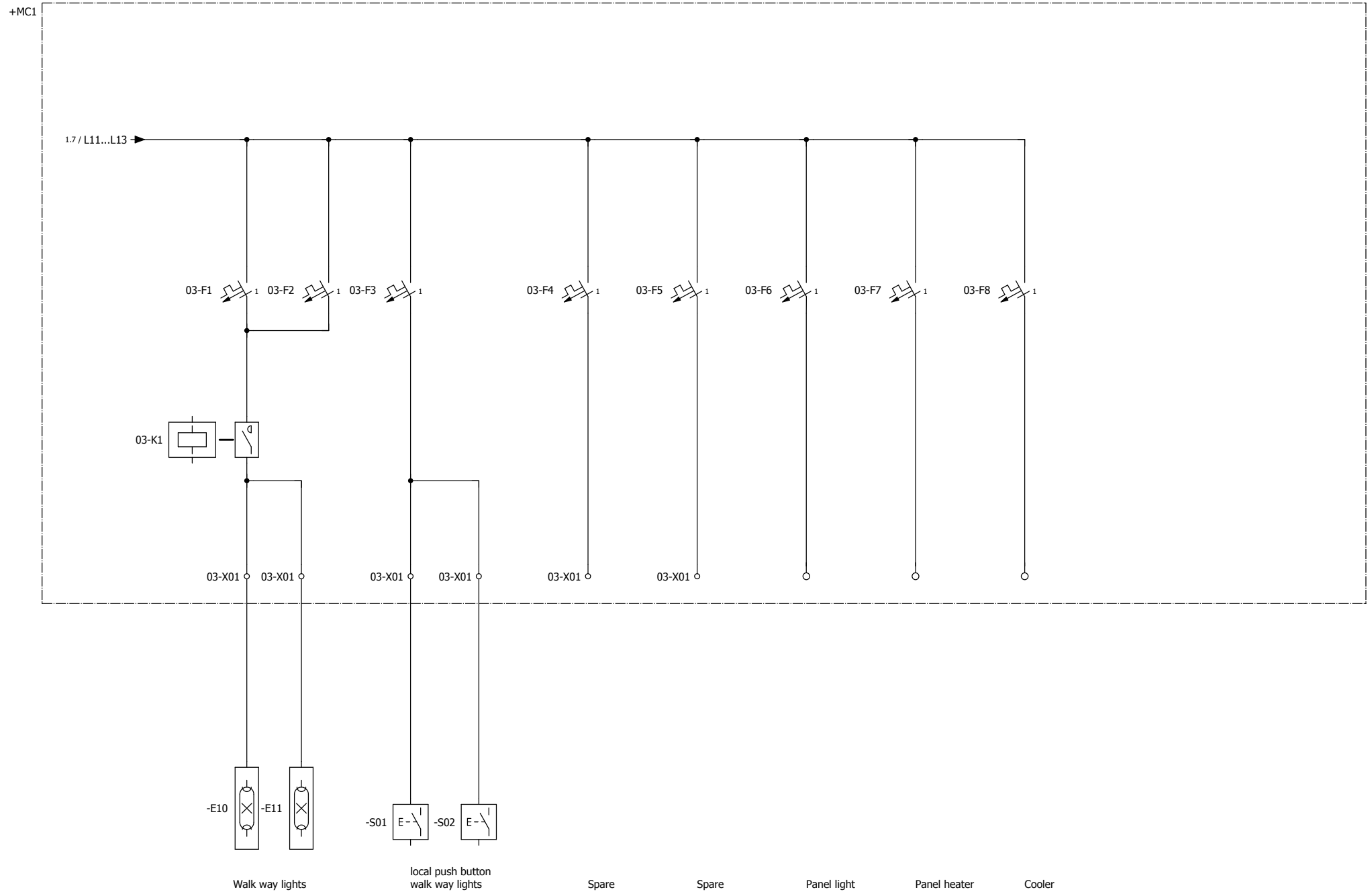

			Date	20.10.2010	Tripper car 523 TR 01		Single line	20.230	= 523TR01
			Ed.	Schmidt				28/04/2010	+ SIN
			Appr	Dauterstedt				12345	Page 2 of 3
Modification	Date	Name	Original	Replacement of	Replaced by				014

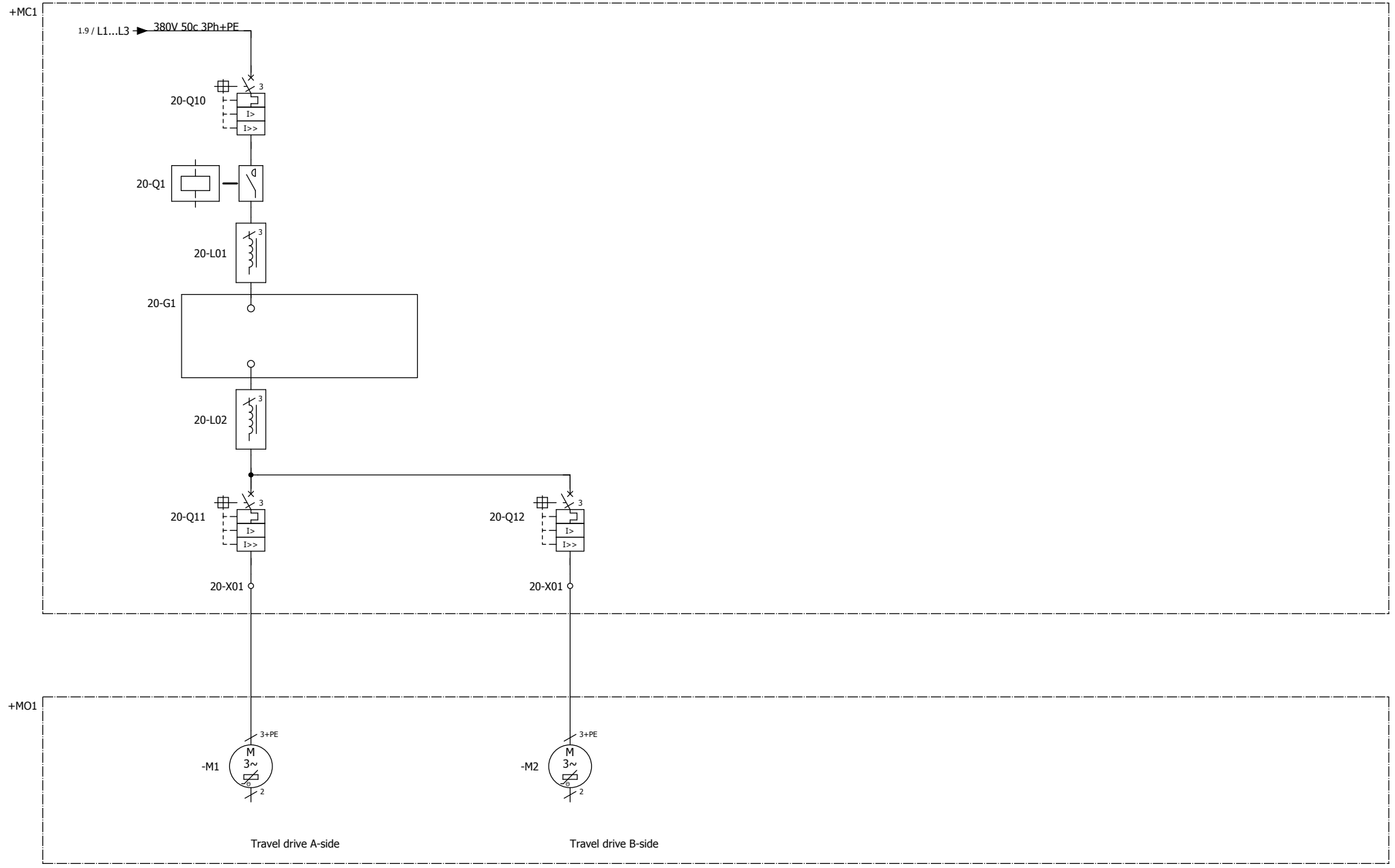

			Date	20.10.2010	<b>Tripper car 523 TR 01</b> <b>Tonasa</b>		Single line	20.230	= 523TR01
			Ed.	Schmidt				28/04/2010	+ SIN
			Appr	Dauterstedt				12345	Page 3 of 3
Modification	Date	Name	Original	Replacement of	Replaced by				015

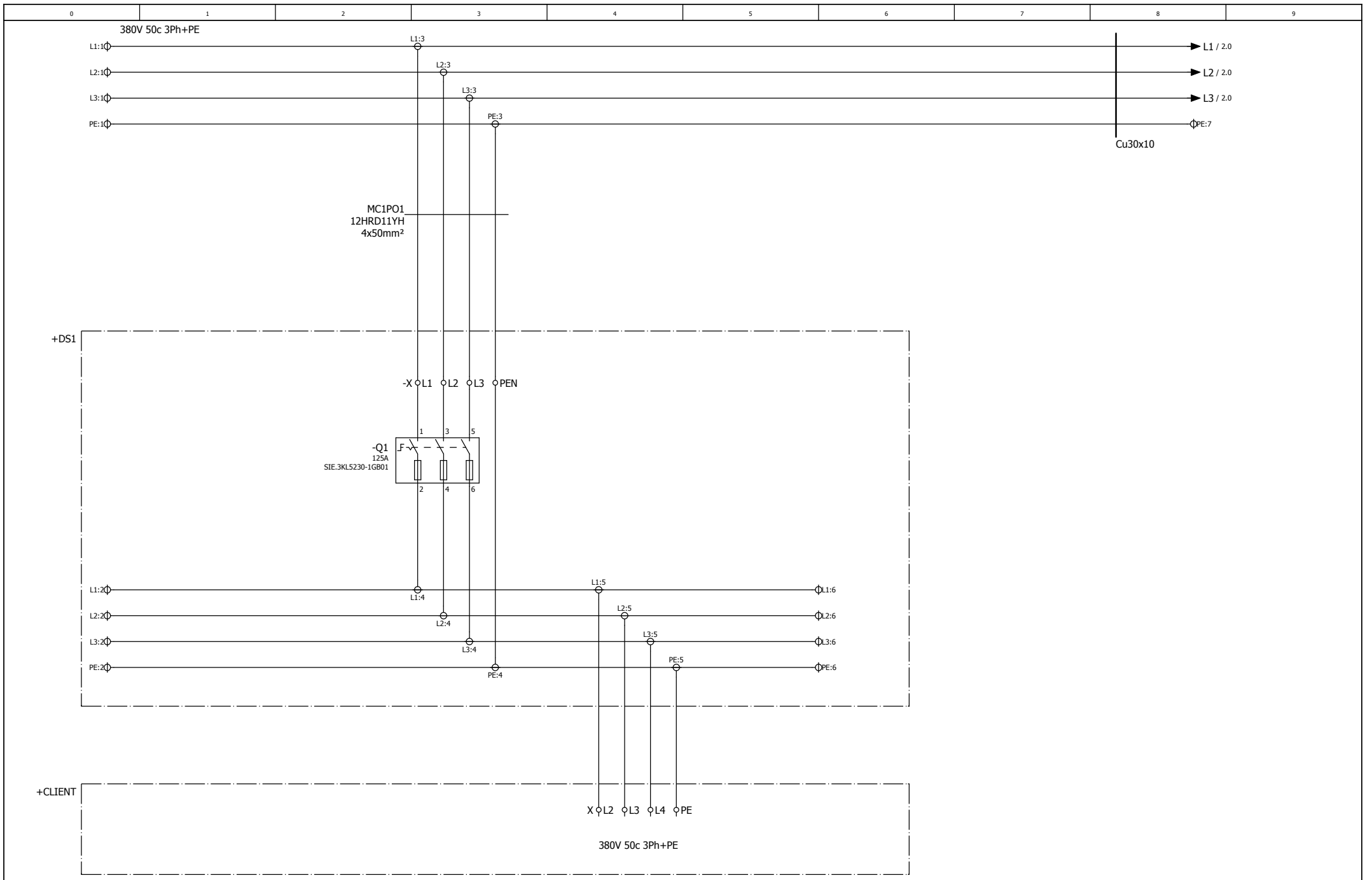

+SIN/3

Date	20.10.2010
Ed.	Schmidt
Appr	Dauterstedt
Original	

Tripper car 523 TR 01  
Tonasa

Replacement of \_\_\_\_\_ Replaced by \_\_\_\_\_



Power supply

20.230	= 523TR01
28/04/2010	+ MC1.01
12345	Page 1 of 5
	016

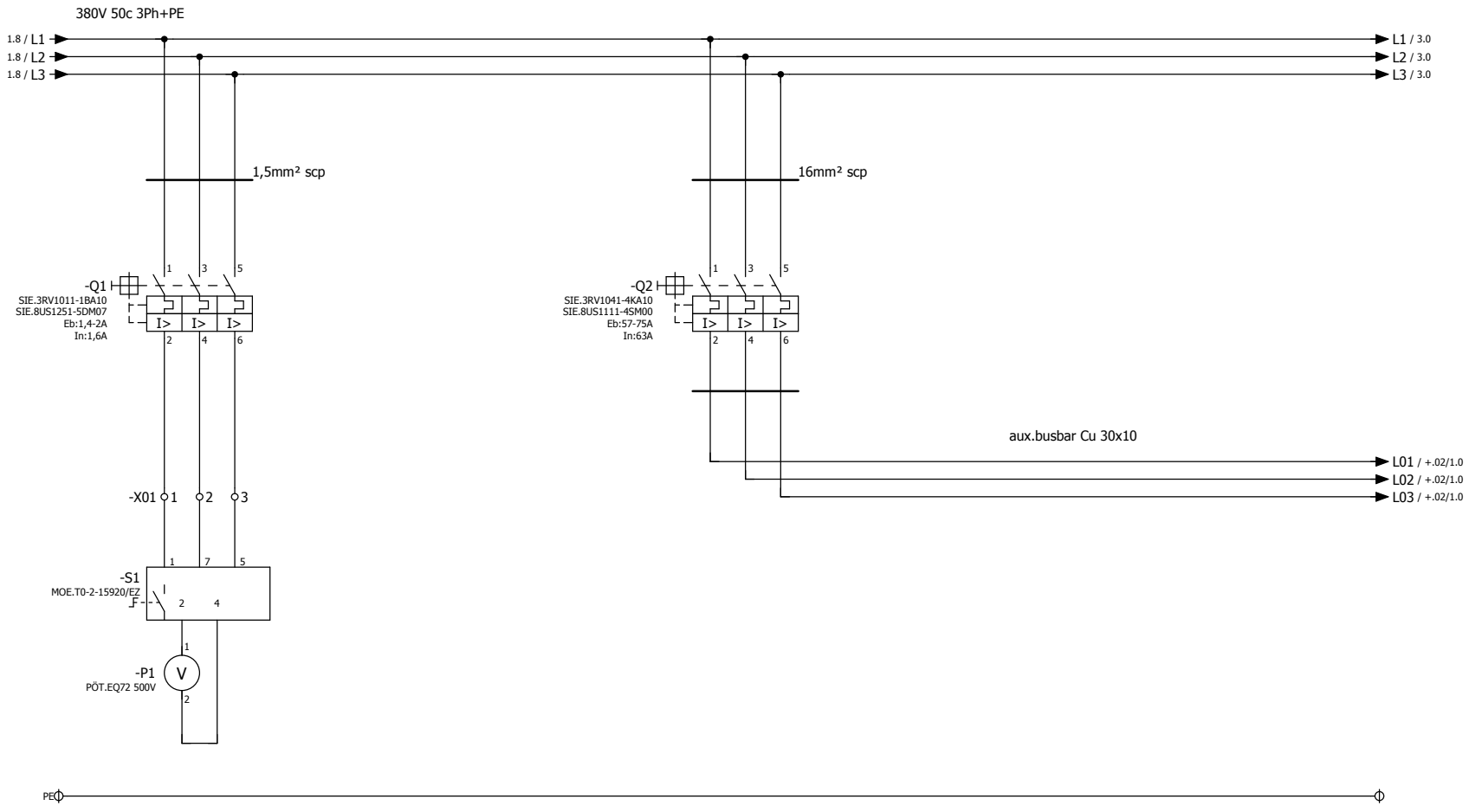

voltage measuring  
inside panel door

			Date	20.10.2010	Tripper car 523 TR 01 Tonasa		Power supply		20.230	= 523TR01
			Ed.	Schmidt					28/04/2010	+ MC1.01
			Appr	Dauterstedt					12345	Page 2 of 5
Modification	Date	Name	Original	Replacement of	Replaced by					017

380V 50c 3Ph+PE

L1 / +20/1.0  
 L2 / +20/1.0  
 L3 / +20/1.0

-T1  
 MBS-7045  
 100/5A

-T2  
 MBS-7045  
 100/5A

-T3  
 MBS-7045  
 100/5A

-XA2  
 SV 9342.240

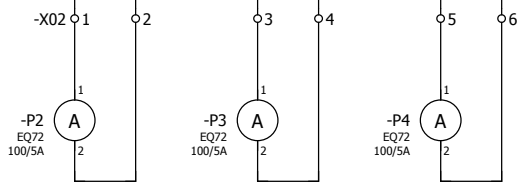

-Q3  
 3VL2710-1DC33-2SB1  
 3VL9330-3HG05  
 3VL9300-8CB30  
 100A

50²

50²

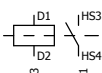

2.7 / L1  
 2.7 / L2  
 2.7 / L3

PE

current measuring  
 inside panel door

			Date	20.10.2010	Tripper car 523 TR 01 Tonasa		Main power switch		20.230	= 523TR01
			Ed.	Schmidt					28/04/2010	+ MC1.01
			Appr	Dauterstedt					12345	Page 3 of 5
Modification	Date	Name	Original		Replacement of	Replaced by				018

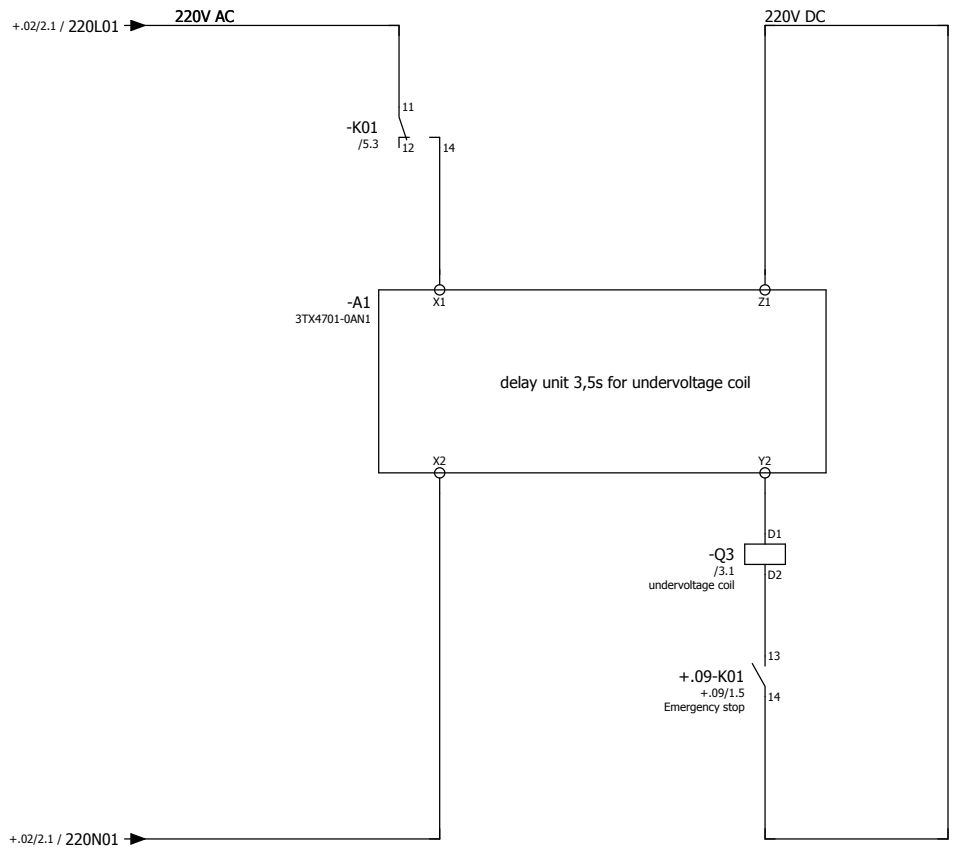

Modification	Date	Name	Original	Replacement of	Replaced by		Main power switch	20.230	= 523TR01
								28/04/2010	+ MC1.01
								12345	Page 4 of 5
									019

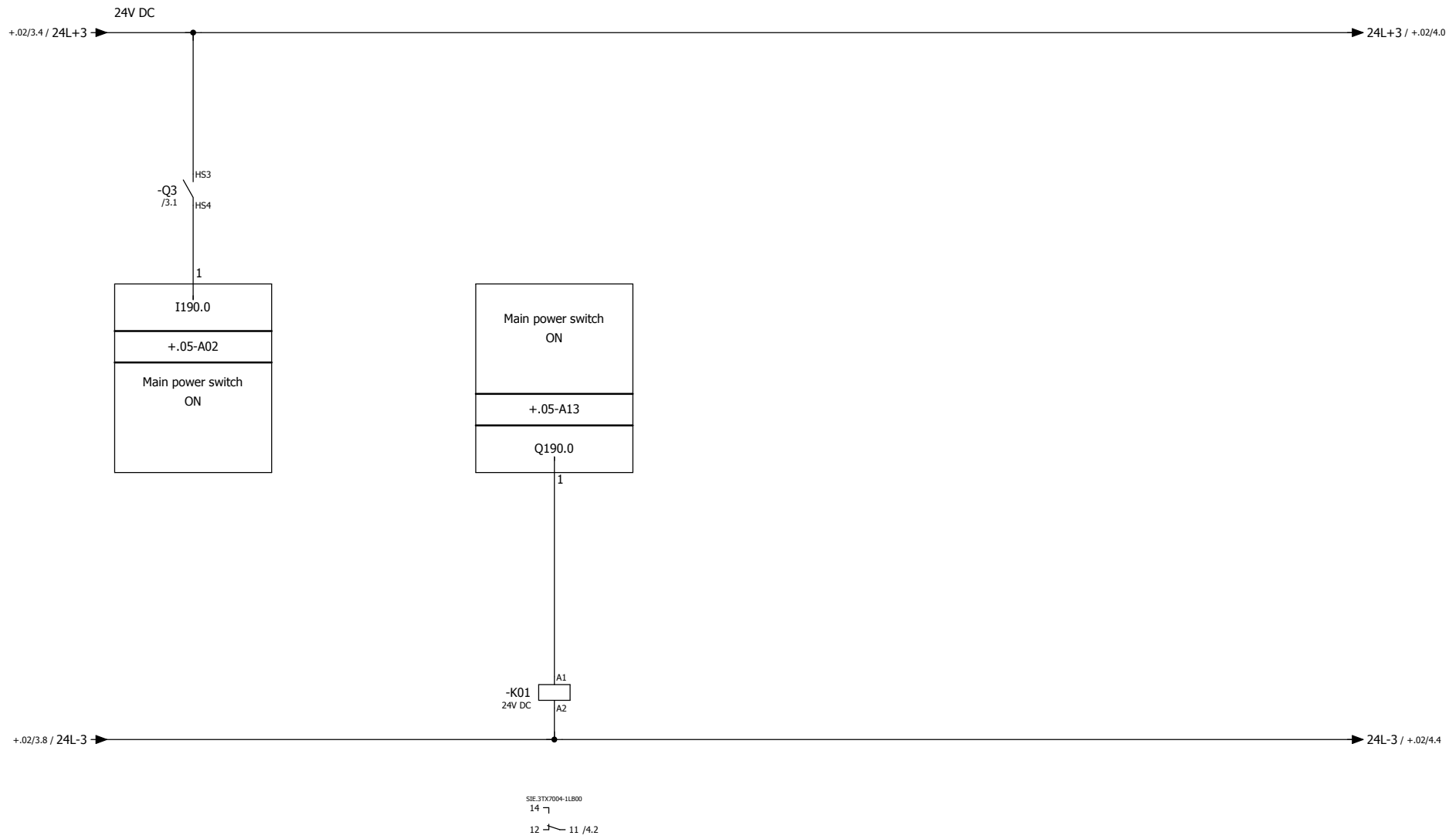

4

+.02/1

			Date	20.10.2010	Tripper car 523 TR 01 Tonasa	<b>SCHADE</b> AUMUND GROUP	Digital input/ output	20.230	= 523TR01
			Ed.	Schmidt				28/04/2010	+ MC1.01
			Appr	Dauterstedt				12345	Page 5 of 5
Modification	Date	Name	Original	Replacement of	Replaced by				020

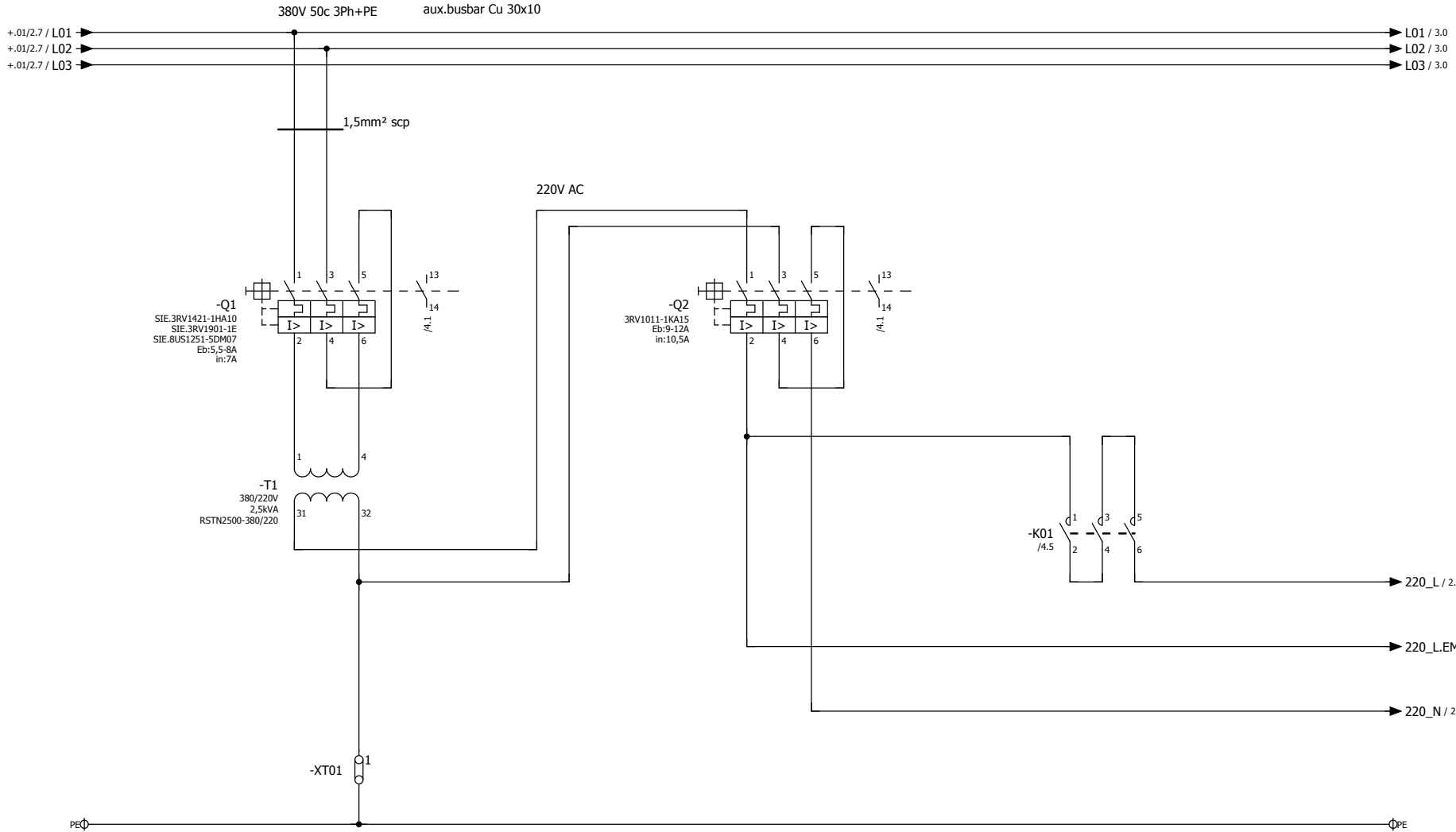

if the clamp is going to take away it is necessary to install an isolation monitoring device.

			Date	20.10.2010	Tripper car 523 TR 01 Tonasa		Control voltage 220V AC		20.230	= 523TR01
			Ed.	Schmidt					28/04/2010	+ MC1.02
			Appr	Dauterstedt					12345	Page 1 of 4
Modification	Date	Name	Original	Replacement of	Replaced by					021

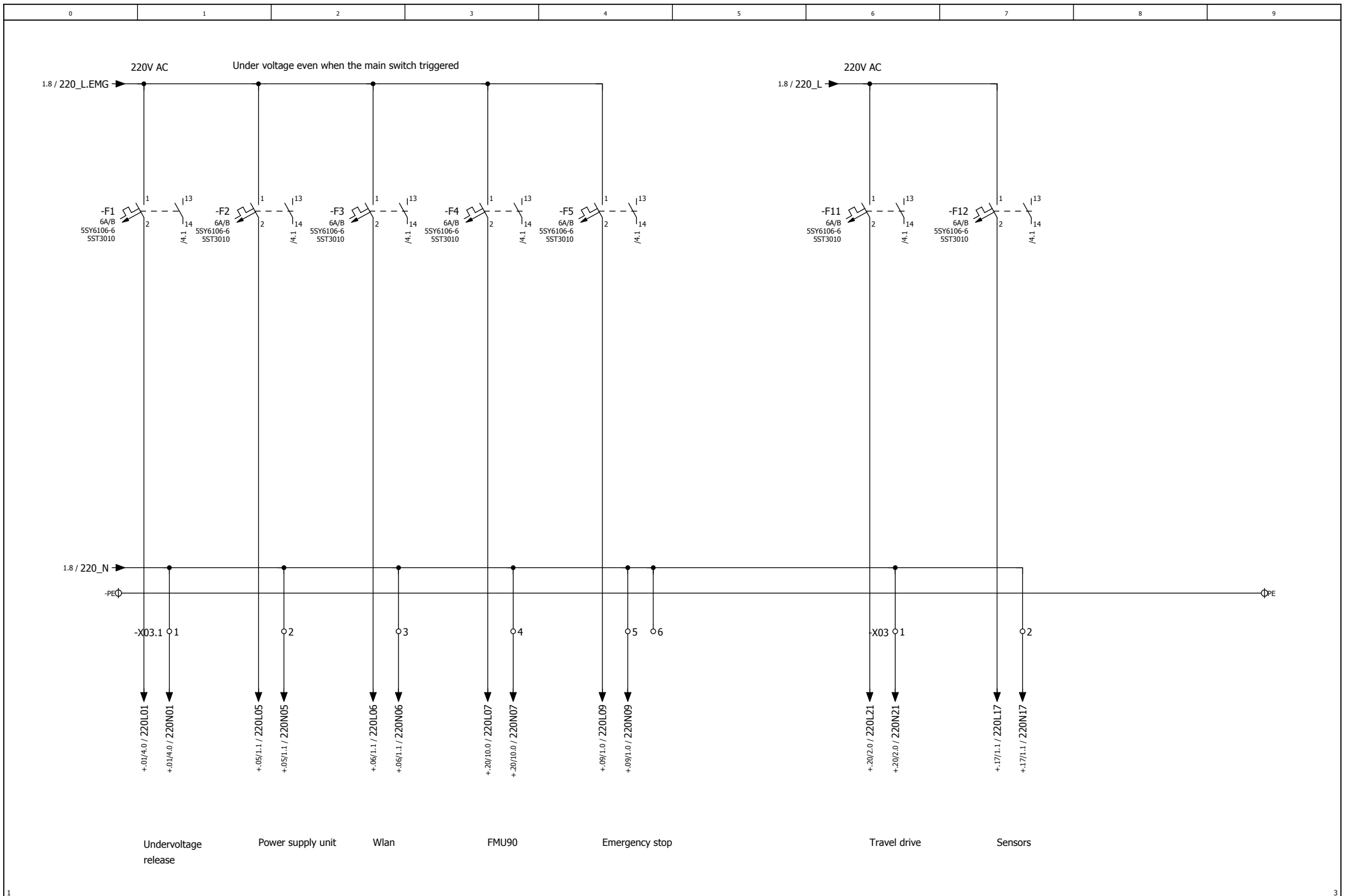

1		3						
Date	20.10.2010	Tripper car 523 TR 01						
Ed.	Schmidt							
Appr	Dauterstedt							
Modification	Date	Name	Original	Replacement of	Replaced by	Control voltage 220V AC	20.230	= 523TR01
							28/04/2010	+ MC1.02
							12345	Page 2 of 4
								022

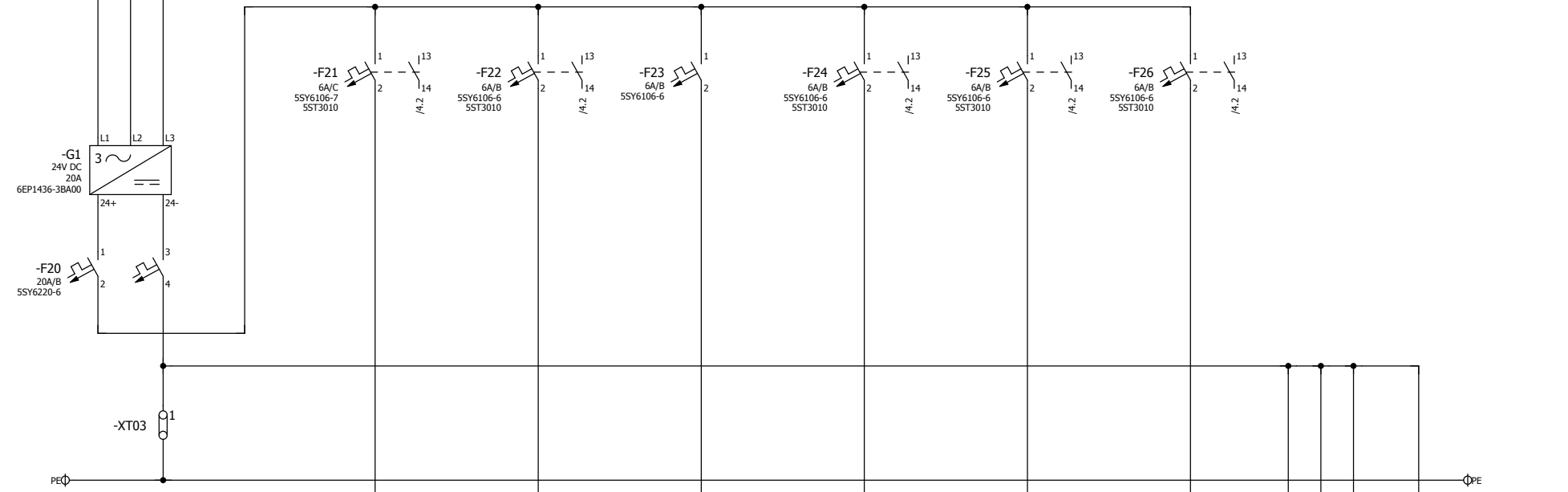
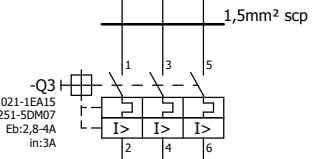
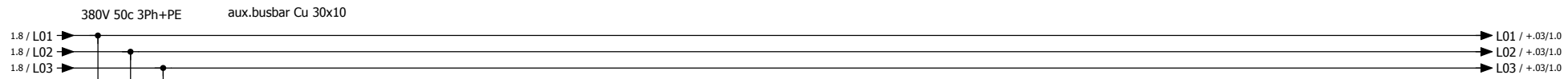

if the clamp is going to take away it is necessary to install an insulation monitoring device.

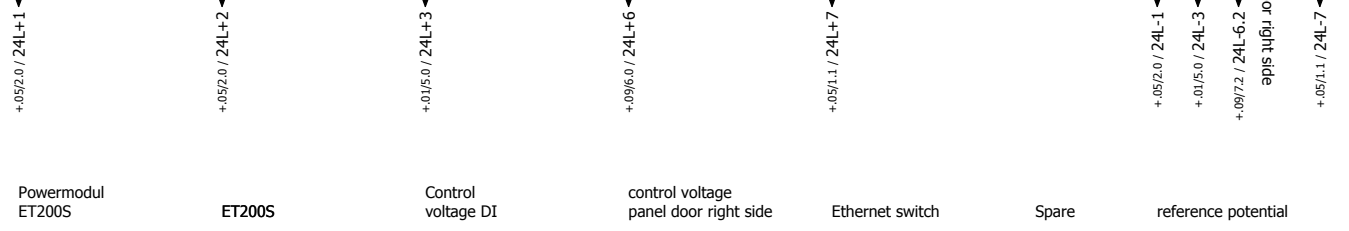

Modification	Date	Name	Original	Replacement of	Replaced by		Control voltage 24V DC	20.230	= 523TR01
								28/04/2010	+ MC1.02
								12345	Page 3 of 4
									923

+01/5.8 / 24L+3 → 24V DC → 24L+3 / +.09/5.0

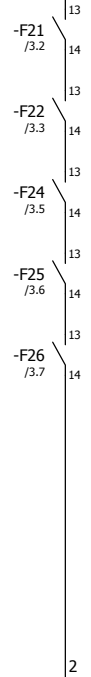
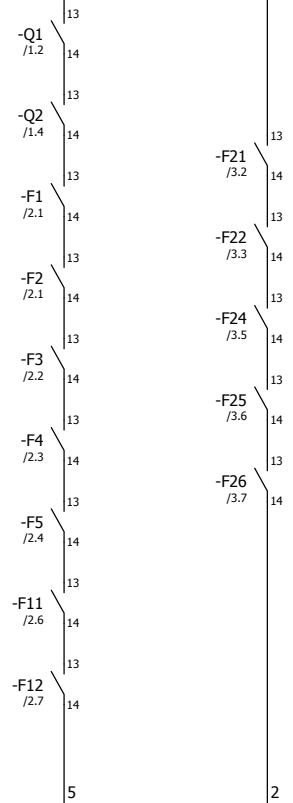

I190.1	I190.2
+ .05-A02	+ .05-A02
Circuit breakers 220V AC are closed	Circuit breakers 24V DC are closed

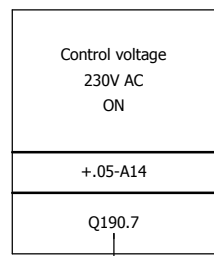

+01/5.8 / 24L-3 → 24L-3 / +.09/6.0

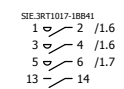

			Date	20.10.2010	Tripper car 523 TR 01 Tonasa		Digital inputs / outputs		20.230	= 523TR01
			Ed.	Schmidt					28/04/2010	+ MC1.02
			Appr	Dauterstedt					12345	Page 4 of 4
Modification	Date	Name	Original	Replacement of	Replaced by					024

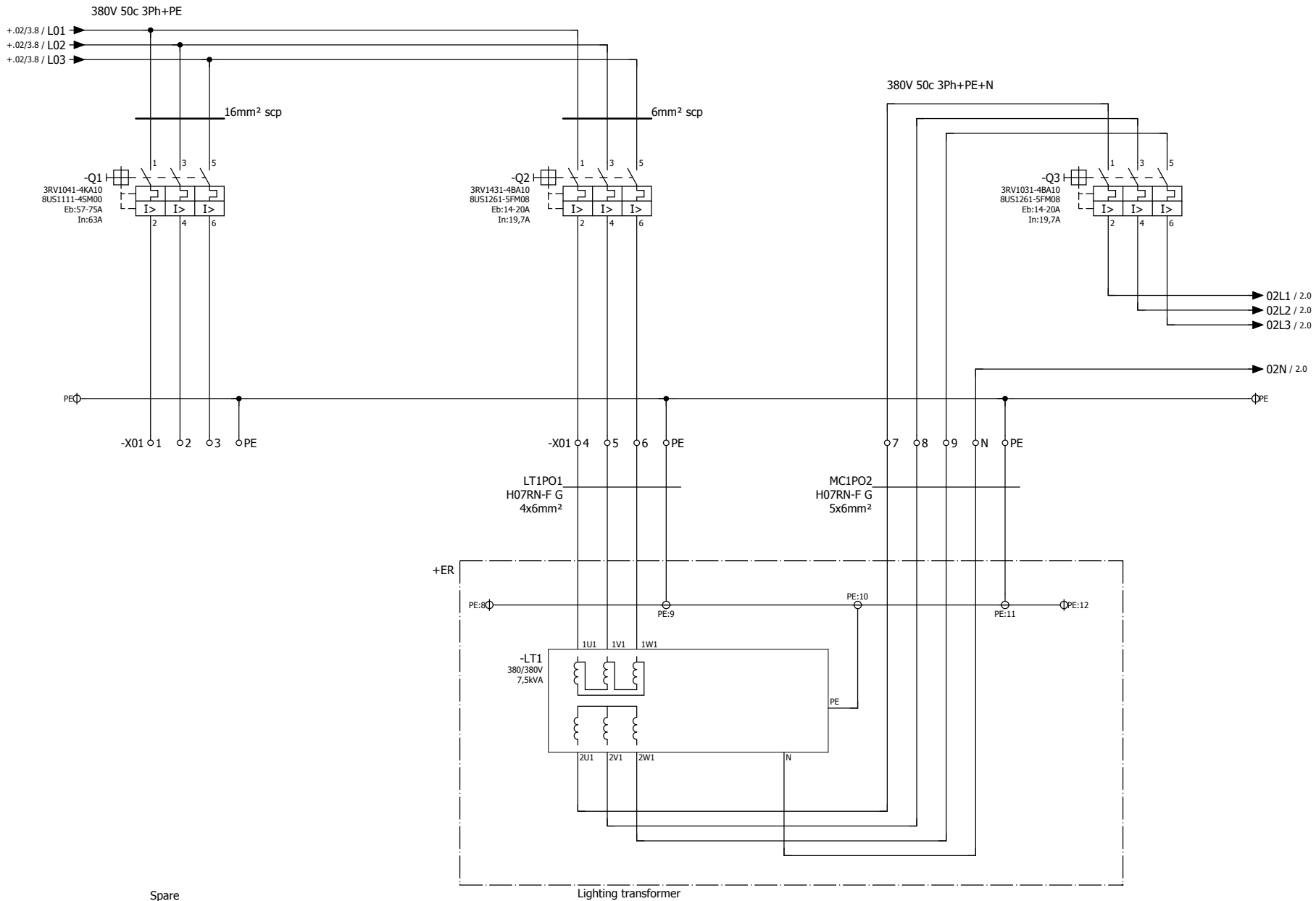

+02/4

Modification	Date	Name	Original	Replacement of	Replaced by

Date: 20.10.2010  
 Ed.: Schmidt  
 Appr.: Dauterstedt

Tripper car 523 TR 01  
 Tonasa



Lighting transformer

20.230 = 523TR01  
 28/04/2010 + MC1.03  
 12345 Page 1 of 2

2

025

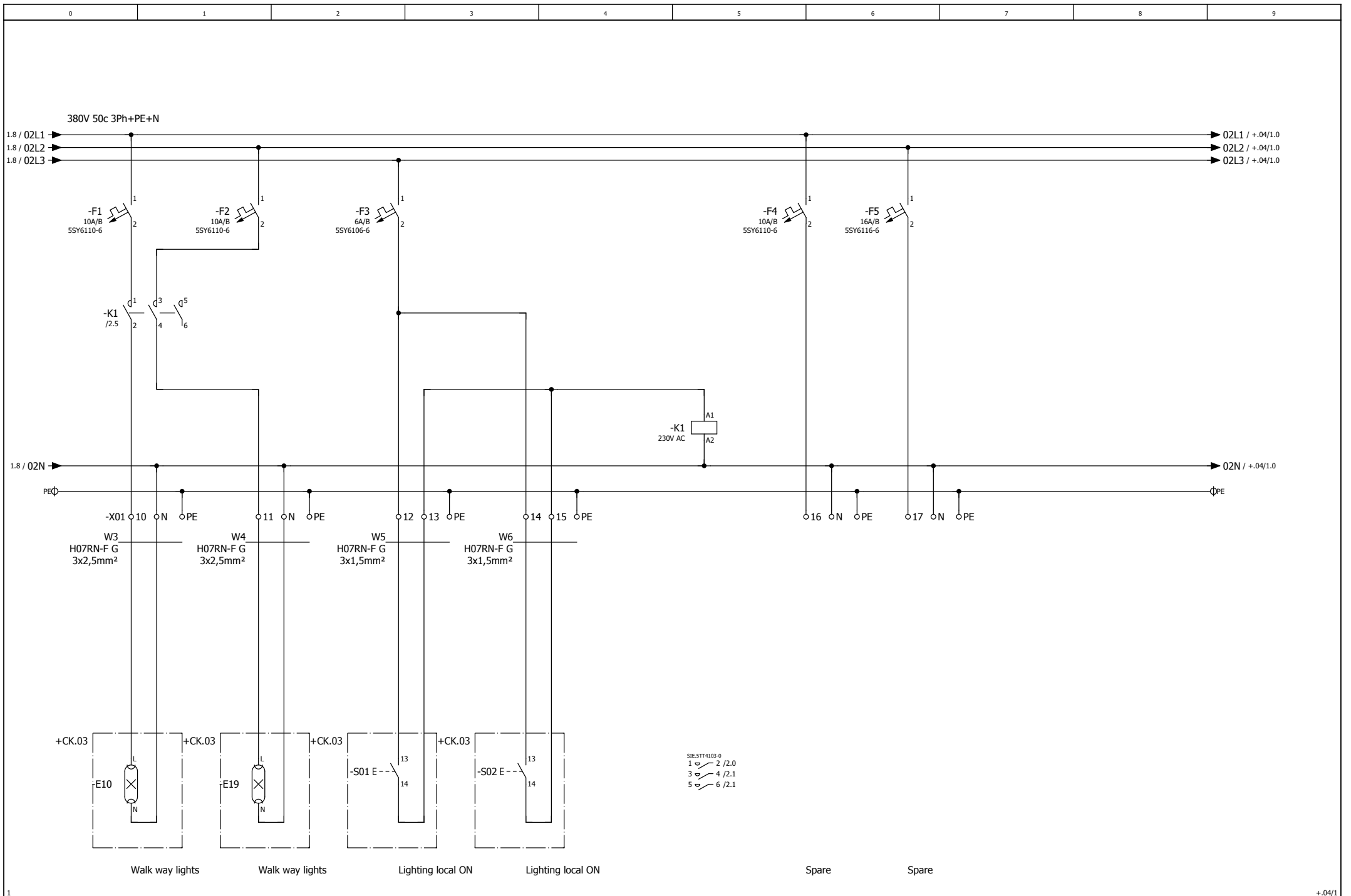

		Date	20.10.2010	Tripper car 523 TR 01			Lighting circuit	20.230	= 523TR01
		Ed.	Schmidt	Tonasa			28/04/2010	+ MC1.03	
		Appr	Dauterstedt				12345	Page 2 of 2	
Modification	Date	Name	Original	Replacement of	Replaced by				026

+04/1

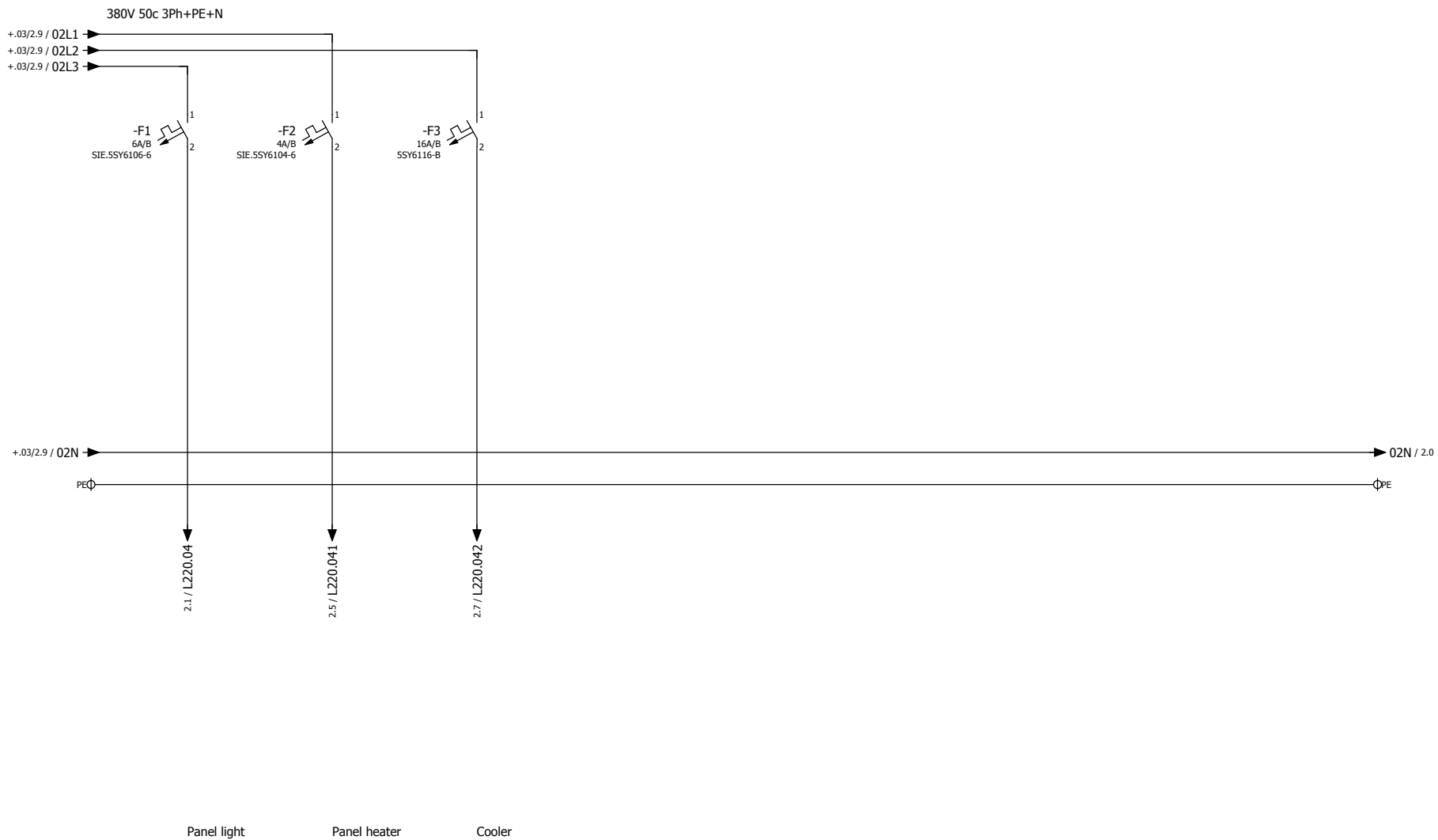

+03/2

Modification	Date	Name	Original	Replacement of	Replaced by

Date	20.10.2010
Ed.	Schmidt
Appr	Dauterstedt
Tripper car 523 TR 01 Tonasa	



Lighting circuit	
------------------	--

20.230	= 523TR01
28/04/2010	+ MC1.04
12345	Page 1 of 2
	027

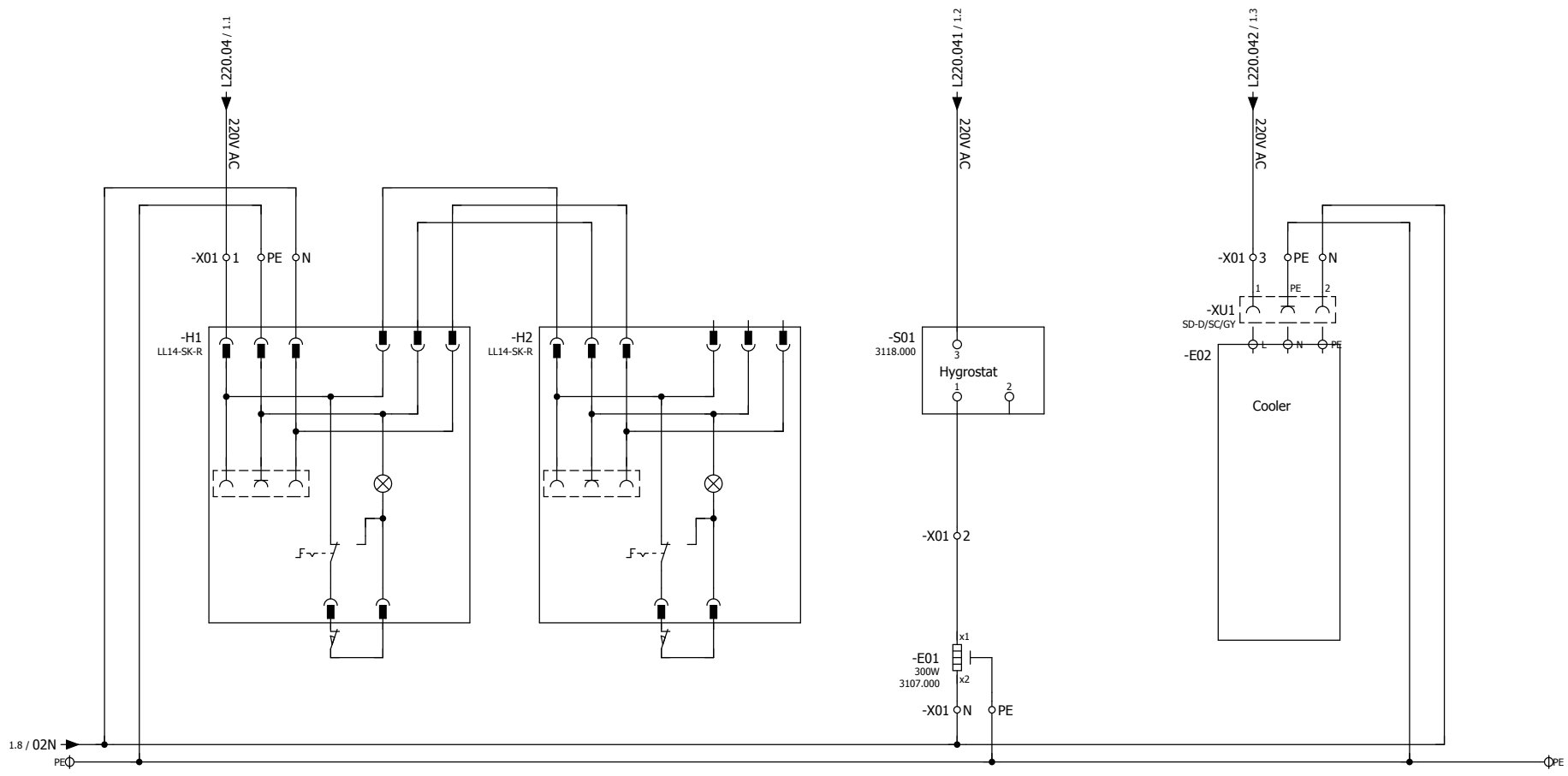

1

Modification	Date	Name	Original	Replacement of	Replaced by

Date 20.10.2010  
 Ed. Schmidt  
 Appr. Dauterstedt  
**Tripper car 523 TR 01**  
**Tonasa**



Panel lights, heater and cooler

20.230	= 523TR01
28/04/2010	+ MC1.04
12345	Page 2 of 2

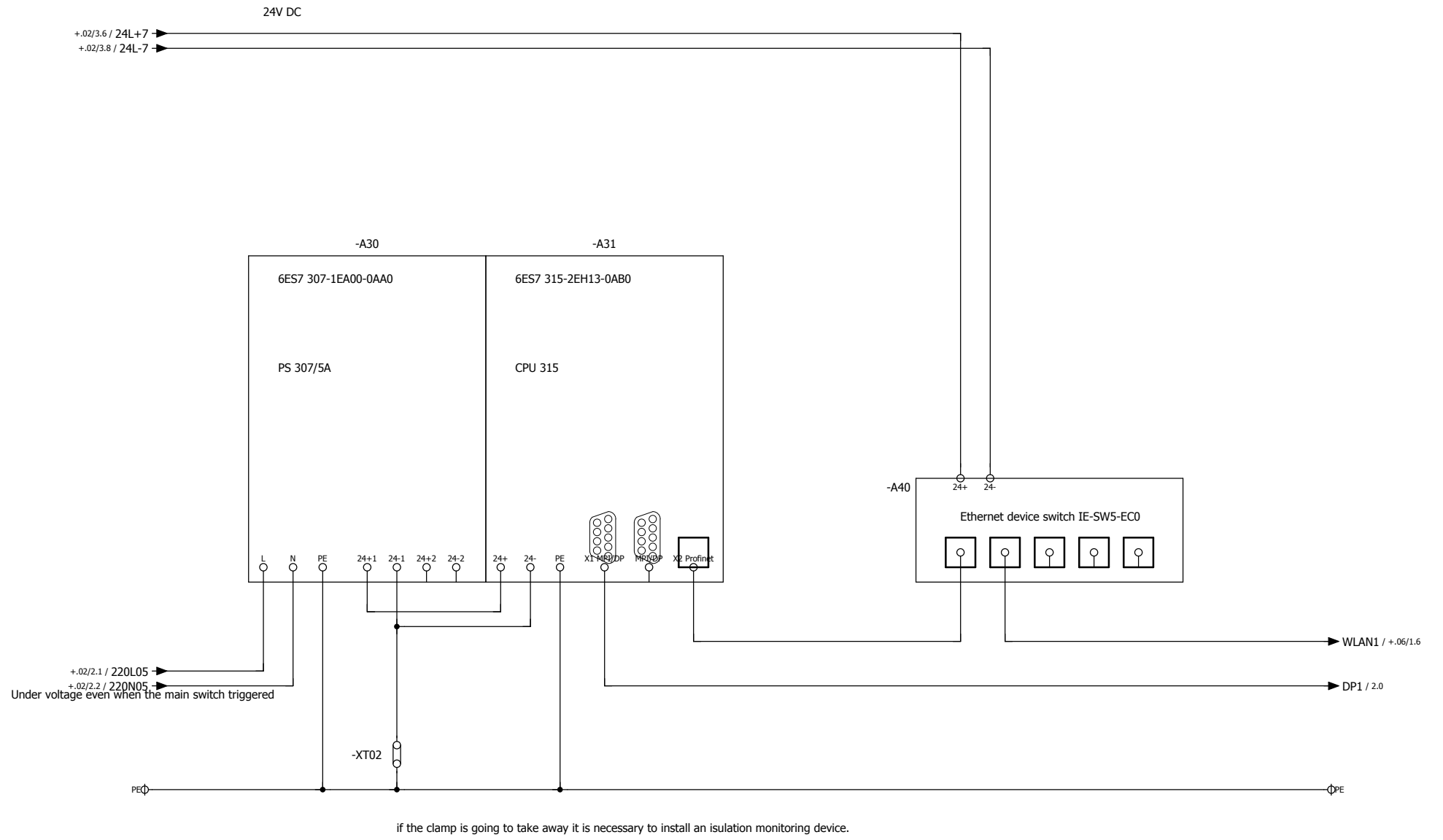

+ .04/2

Modification	Date	Name	Original	Replacement of	Replaced by		Basic-Rack	20.230	= 523TR01
								28/04/2010	+ MC1.05
								12345	Page 1 of 6
									029

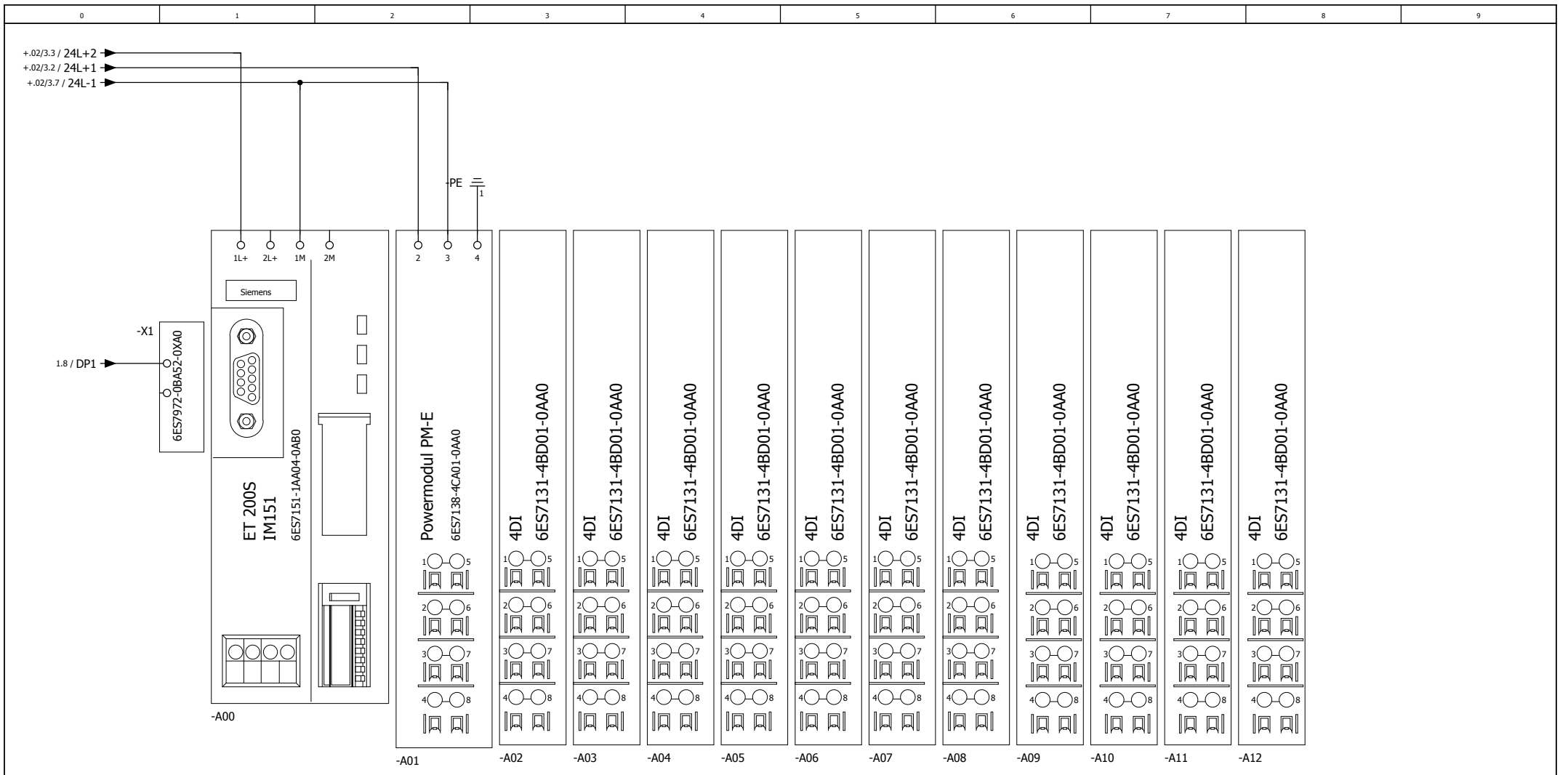

			Date	20.10.2010	Tripper car 523 TR 01 Tonasa		ET200S		20.230	= 523TR01
			Ed.	Schmidt					28/04/2010	+ MC1.05
			Appr	Dauterstedt					12345	Page 2 of 6
Modification	Date	Name	Original	Replacement of	Replaced by					030

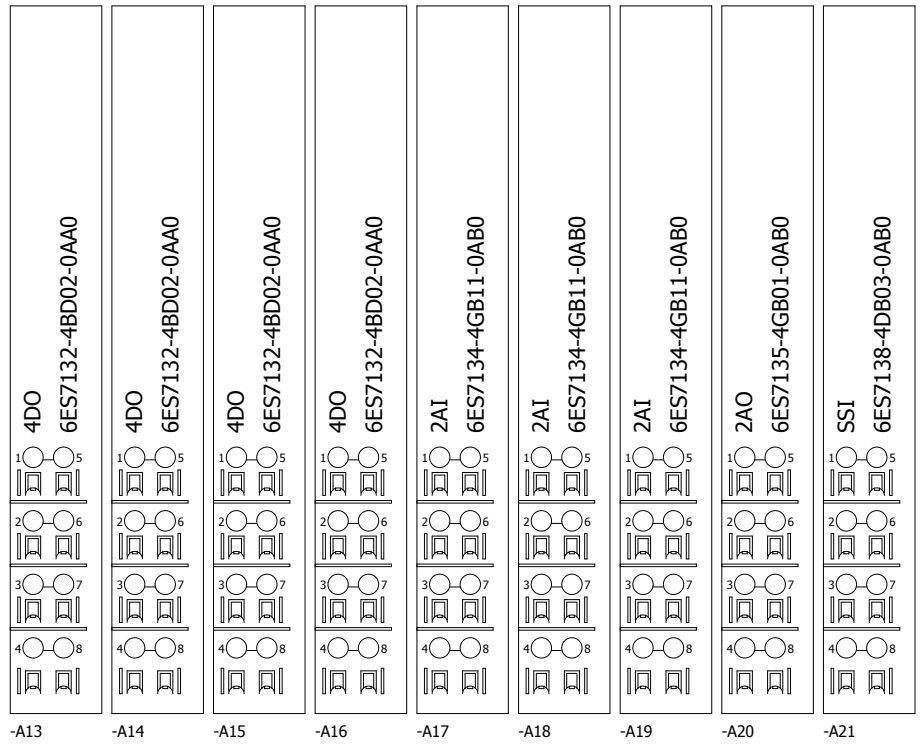

			Date	20.10.2010	<b>Tripper car 523 TR 01</b> <b>Tonasa</b>		ET200S		20.230	= 523TR01	
			Ed.	Schmidt						28/04/2010	+ MC1.05
			Appr	Dauterstedt						12345	Page 3 of 6
Modification	Date	Name	Original	Replacement of	Replaced by					031	

-A02	<table border="1" style="width:100%; border-collapse: collapse;"> <tr><td style="width:10%;">I190.0</td><td style="width:5%; text-align: center;">1</td><td style="width:5%; text-align: center;">5</td></tr> <tr><td>I190.1</td><td style="text-align: center;">5</td><td style="text-align: center;">2</td></tr> <tr><td>I190.2</td><td style="text-align: center;">2</td><td style="text-align: center;">6</td></tr> <tr><td>I190.3</td><td style="text-align: center;">6</td><td></td></tr> </table>	I190.0	1	5	I190.1	5	2	I190.2	2	6	I190.3	6		<table border="1" style="width:100%; border-collapse: collapse;"> <tr><td style="width:10%;">+01/5.1</td><td style="width:10%;">+01-Q3:HS4</td></tr> <tr><td>+02/4.1</td><td>+02-F12:14</td></tr> <tr><td>+02/4.2</td><td>+02-F26:14</td></tr> </table>	+01/5.1	+01-Q3:HS4	+02/4.1	+02-F12:14	+02/4.2	+02-F26:14	<table border="1" style="width:100%; border-collapse: collapse;"> <tr><td style="width:100%;">Main power switch ON</td></tr> <tr><td>Circuit breakers 220V AC are closed</td></tr> <tr><td>Circuit breakers 24V DC are closed</td></tr> </table>	Main power switch ON	Circuit breakers 220V AC are closed	Circuit breakers 24V DC are closed			
I190.0	1	5																									
I190.1	5	2																									
I190.2	2	6																									
I190.3	6																										
+01/5.1	+01-Q3:HS4																										
+02/4.1	+02-F12:14																										
+02/4.2	+02-F26:14																										
Main power switch ON																											
Circuit breakers 220V AC are closed																											
Circuit breakers 24V DC are closed																											
-A03	<table border="1" style="width:100%; border-collapse: collapse;"> <tr><td style="width:10%;">I190.4</td><td style="width:5%; text-align: center;">1</td><td style="width:5%; text-align: center;">5</td></tr> <tr><td>I190.5</td><td style="text-align: center;">5</td><td style="text-align: center;">2</td></tr> <tr><td>I190.6</td><td style="text-align: center;">2</td><td style="text-align: center;">6</td></tr> <tr><td>I190.7</td><td style="text-align: center;">6</td><td></td></tr> </table>	I190.4	1	5	I190.5	5	2	I190.6	2	6	I190.7	6		<table border="1" style="width:100%; border-collapse: collapse;"> <tr><td style="width:10%;">+09/5.0</td><td style="width:10%;">+09-K01:24</td></tr> <tr><td>+09/5.1</td><td>+09-S50:32</td></tr> <tr><td>+09/5.2</td><td>+09-K61:14</td></tr> <tr><td>+09/5.3</td><td>+09-K62:14</td></tr> </table>	+09/5.0	+09-K01:24	+09/5.1	+09-S50:32	+09/5.2	+09-K61:14	+09/5.3	+09-K62:14	<table border="1" style="width:100%; border-collapse: collapse;"> <tr><td style="width:100%;">Emergency stop relay is ON</td></tr> <tr><td>Emergency stop pushbutton 1 panel door not pushed</td></tr> <tr><td>Emergency stop pushbutton 2 not pushed</td></tr> <tr><td>Emergency stop pushbutton 3 not pushed</td></tr> </table>	Emergency stop relay is ON	Emergency stop pushbutton 1 panel door not pushed	Emergency stop pushbutton 2 not pushed	Emergency stop pushbutton 3 not pushed
I190.4	1	5																									
I190.5	5	2																									
I190.6	2	6																									
I190.7	6																										
+09/5.0	+09-K01:24																										
+09/5.1	+09-S50:32																										
+09/5.2	+09-K61:14																										
+09/5.3	+09-K62:14																										
Emergency stop relay is ON																											
Emergency stop pushbutton 1 panel door not pushed																											
Emergency stop pushbutton 2 not pushed																											
Emergency stop pushbutton 3 not pushed																											
-A04	<table border="1" style="width:100%; border-collapse: collapse;"> <tr><td style="width:10%;">I191.0</td><td style="width:5%; text-align: center;">1</td><td style="width:5%; text-align: center;">5</td></tr> <tr><td>I191.1</td><td style="text-align: center;">5</td><td style="text-align: center;">2</td></tr> <tr><td>I191.2</td><td style="text-align: center;">2</td><td style="text-align: center;">6</td></tr> <tr><td>I191.3</td><td style="text-align: center;">6</td><td></td></tr> </table>	I191.0	1	5	I191.1	5	2	I191.2	2	6	I191.3	6		<table border="1" style="width:100%; border-collapse: collapse;"> <tr><td style="width:10%;">+09/5.4</td><td style="width:10%;">+09-K63:14</td></tr> <tr><td>+09/5.5</td><td>+09-K64:14</td></tr> <tr><td>+09/5.6</td><td>+09-K65:14</td></tr> <tr><td>+09/5.7</td><td>+09-K66:14</td></tr> </table>	+09/5.4	+09-K63:14	+09/5.5	+09-K64:14	+09/5.6	+09-K65:14	+09/5.7	+09-K66:14	<table border="1" style="width:100%; border-collapse: collapse;"> <tr><td style="width:100%;">Emergency stop pushbutton 4 not pushed</td></tr> <tr><td>Emergency stop pushbutton 5 not pushed</td></tr> <tr><td>Pullrope switch closed</td></tr> <tr><td>Pull rope switch left closed</td></tr> </table>	Emergency stop pushbutton 4 not pushed	Emergency stop pushbutton 5 not pushed	Pullrope switch closed	Pull rope switch left closed
I191.0	1	5																									
I191.1	5	2																									
I191.2	2	6																									
I191.3	6																										
+09/5.4	+09-K63:14																										
+09/5.5	+09-K64:14																										
+09/5.6	+09-K65:14																										
+09/5.7	+09-K66:14																										
Emergency stop pushbutton 4 not pushed																											
Emergency stop pushbutton 5 not pushed																											
Pullrope switch closed																											
Pull rope switch left closed																											
-A05	<table border="1" style="width:100%; border-collapse: collapse;"> <tr><td style="width:10%;">I191.4</td><td style="width:5%; text-align: center;">1</td><td style="width:5%; text-align: center;">5</td></tr> <tr><td>I191.5</td><td style="text-align: center;">5</td><td style="text-align: center;">2</td></tr> <tr><td>I191.6</td><td style="text-align: center;">2</td><td style="text-align: center;">6</td></tr> <tr><td>I191.7</td><td style="text-align: center;">6</td><td></td></tr> </table>	I191.4	1	5	I191.5	5	2	I191.6	2	6	I191.7	6		<table border="1" style="width:100%; border-collapse: collapse;"> <tr><td style="width:10%;">+09/6.1</td><td style="width:10%;">+09-S1:12</td></tr> <tr><td>+09/6.2</td><td>+09-S1:14</td></tr> <tr><td>+09/6.3</td><td>+09-S2:14</td></tr> <tr><td>+09/6.4</td><td>+09-S3:12</td></tr> </table>	+09/6.1	+09-S1:12	+09/6.2	+09-S1:14	+09/6.3	+09-S2:14	+09/6.4	+09-S3:12	<table border="1" style="width:100%; border-collapse: collapse;"> <tr><td style="width:100%;">Manual mode selected</td></tr> <tr><td>Automatic mode selected</td></tr> <tr><td>Control ON</td></tr> <tr><td>Control OFF</td></tr> </table>	Manual mode selected	Automatic mode selected	Control ON	Control OFF
I191.4	1	5																									
I191.5	5	2																									
I191.6	2	6																									
I191.7	6																										
+09/6.1	+09-S1:12																										
+09/6.2	+09-S1:14																										
+09/6.3	+09-S2:14																										
+09/6.4	+09-S3:12																										
Manual mode selected																											
Automatic mode selected																											
Control ON																											
Control OFF																											
-A06	<table border="1" style="width:100%; border-collapse: collapse;"> <tr><td style="width:10%;">I192.0</td><td style="width:5%; text-align: center;">1</td><td style="width:5%; text-align: center;">5</td></tr> <tr><td>I192.1</td><td style="text-align: center;">5</td><td style="text-align: center;">2</td></tr> <tr><td>I192.2</td><td style="text-align: center;">2</td><td style="text-align: center;">6</td></tr> <tr><td>I192.3</td><td style="text-align: center;">6</td><td></td></tr> </table>	I192.0	1	5	I192.1	5	2	I192.2	2	6	I192.3	6		<table border="1" style="width:100%; border-collapse: collapse;"> <tr><td style="width:10%;">+09/6.5</td><td style="width:10%;">+09-S4:14</td></tr> <tr><td>+09/6.8</td><td>+09-K36:24</td></tr> <tr><td>+09/5.8</td><td>+09-K67:14</td></tr> <tr><td>+09/5.9</td><td>+09-K68:14</td></tr> </table>	+09/6.5	+09-S4:14	+09/6.8	+09-K36:24	+09/5.8	+09-K67:14	+09/5.9	+09-K68:14	<table border="1" style="width:100%; border-collapse: collapse;"> <tr><td style="width:100%;">Lampstest</td></tr> <tr><td>Reset</td></tr> <tr><td>Emergency stop 244BC07</td></tr> <tr><td>Emergency stop 244BC07</td></tr> </table>	Lampstest	Reset	Emergency stop 244BC07	Emergency stop 244BC07
I192.0	1	5																									
I192.1	5	2																									
I192.2	2	6																									
I192.3	6																										
+09/6.5	+09-S4:14																										
+09/6.8	+09-K36:24																										
+09/5.8	+09-K67:14																										
+09/5.9	+09-K68:14																										
Lampstest																											
Reset																											
Emergency stop 244BC07																											
Emergency stop 244BC07																											
-A07	<table border="1" style="width:100%; border-collapse: collapse;"> <tr><td style="width:10%;">I192.4</td><td style="width:5%; text-align: center;">1</td><td style="width:5%; text-align: center;">5</td></tr> <tr><td>I192.5</td><td style="text-align: center;">5</td><td style="text-align: center;">2</td></tr> <tr><td>I192.6</td><td style="text-align: center;">2</td><td style="text-align: center;">6</td></tr> <tr><td>I192.7</td><td style="text-align: center;">6</td><td></td></tr> </table>	I192.4	1	5	I192.5	5	2	I192.6	2	6	I192.7	6		<table border="1" style="width:100%; border-collapse: collapse;"> <tr><td style="width:10%;">+17/2.1</td><td style="width:10%;">+17-K61:14</td></tr> <tr><td>+17/2.2</td><td>+17-K62:14</td></tr> <tr><td>+17/2.3</td><td>+17-K63:14</td></tr> </table>	+17/2.1	+17-K61:14	+17/2.2	+17-K62:14	+17/2.3	+17-K63:14	<table border="1" style="width:100%; border-collapse: collapse;"> <tr><td style="width:100%;">Chute overfiled</td></tr> <tr><td>Misalignment left</td></tr> <tr><td>Misalignment right</td></tr> </table>	Chute overfiled	Misalignment left	Misalignment right			
I192.4	1	5																									
I192.5	5	2																									
I192.6	2	6																									
I192.7	6																										
+17/2.1	+17-K61:14																										
+17/2.2	+17-K62:14																										
+17/2.3	+17-K63:14																										
Chute overfiled																											
Misalignment left																											
Misalignment right																											
-A08	<table border="1" style="width:100%; border-collapse: collapse;"> <tr><td style="width:10%;">I193.0</td><td style="width:5%; text-align: center;">1</td><td style="width:5%; text-align: center;">5</td></tr> <tr><td>I193.1</td><td style="text-align: center;">5</td><td style="text-align: center;">2</td></tr> <tr><td>I193.2</td><td style="text-align: center;">2</td><td style="text-align: center;">6</td></tr> <tr><td>I193.3</td><td style="text-align: center;">6</td><td></td></tr> </table>	I193.0	1	5	I193.1	5	2	I193.2	2	6	I193.3	6		<table border="1" style="width:100%; border-collapse: collapse;"> <tr><td style="width:10%;">+20/4.1</td><td style="width:10%;">+20-S30:12</td></tr> <tr><td>+20/4.2</td><td>+20-S31:14</td></tr> <tr><td>+20/4.3</td><td>+20-S32:14</td></tr> <tr><td>+20/5.0</td><td>+20-Q10:22</td></tr> </table>	+20/4.1	+20-S30:12	+20/4.2	+20-S31:14	+20/4.3	+20-S32:14	+20/5.0	+20-Q10:22	<table border="1" style="width:100%; border-collapse: collapse;"> <tr><td style="width:100%;">Travel drive OFF</td></tr> <tr><td>Travel drive right ON</td></tr> <tr><td>Travel drive left ON</td></tr> <tr><td>Travel drives A+B side circuit breaker not closed</td></tr> </table>	Travel drive OFF	Travel drive right ON	Travel drive left ON	Travel drives A+B side circuit breaker not closed
I193.0	1	5																									
I193.1	5	2																									
I193.2	2	6																									
I193.3	6																										
+20/4.1	+20-S30:12																										
+20/4.2	+20-S31:14																										
+20/4.3	+20-S32:14																										
+20/5.0	+20-Q10:22																										
Travel drive OFF																											
Travel drive right ON																											
Travel drive left ON																											
Travel drives A+B side circuit breaker not closed																											
-A09	<table border="1" style="width:100%; border-collapse: collapse;"> <tr><td style="width:10%;">I193.4</td><td style="width:5%; text-align: center;">1</td><td style="width:5%; text-align: center;">5</td></tr> <tr><td>I193.5</td><td style="text-align: center;">5</td><td style="text-align: center;">2</td></tr> <tr><td>I193.6</td><td style="text-align: center;">2</td><td style="text-align: center;">6</td></tr> <tr><td>I193.7</td><td style="text-align: center;">6</td><td></td></tr> </table>	I193.4	1	5	I193.5	5	2	I193.6	2	6	I193.7	6		<table border="1" style="width:100%; border-collapse: collapse;"> <tr><td style="width:10%;">+20/5.2</td><td style="width:10%;">+20-Q11:22</td></tr> <tr><td>+20/5.2</td><td>+20-Q12:22</td></tr> <tr><td>+20/5.3</td><td>+20-F31:08</td></tr> <tr><td>+20/5.4</td><td>+20-F32:08</td></tr> </table>	+20/5.2	+20-Q11:22	+20/5.2	+20-Q12:22	+20/5.3	+20-F31:08	+20/5.4	+20-F32:08	<table border="1" style="width:100%; border-collapse: collapse;"> <tr><td style="width:100%;">Travel drives A-side circuit breaker not closed</td></tr> <tr><td>Travel drives B-side circuit breaker not closed</td></tr> <tr><td>Travel drive A-side thermistor warning</td></tr> <tr><td>Travel drive B-side thermistor warning</td></tr> </table>	Travel drives A-side circuit breaker not closed	Travel drives B-side circuit breaker not closed	Travel drive A-side thermistor warning	Travel drive B-side thermistor warning
I193.4	1	5																									
I193.5	5	2																									
I193.6	2	6																									
I193.7	6																										
+20/5.2	+20-Q11:22																										
+20/5.2	+20-Q12:22																										
+20/5.3	+20-F31:08																										
+20/5.4	+20-F32:08																										
Travel drives A-side circuit breaker not closed																											
Travel drives B-side circuit breaker not closed																											
Travel drive A-side thermistor warning																											
Travel drive B-side thermistor warning																											
-A10	<table border="1" style="width:100%; border-collapse: collapse;"> <tr><td style="width:10%;">I194.0</td><td style="width:5%; text-align: center;">1</td><td style="width:5%; text-align: center;">5</td></tr> <tr><td>I194.1</td><td style="text-align: center;">5</td><td style="text-align: center;">2</td></tr> <tr><td>I194.2</td><td style="text-align: center;">2</td><td style="text-align: center;">6</td></tr> <tr><td>I194.3</td><td style="text-align: center;">6</td><td></td></tr> </table>	I194.0	1	5	I194.1	5	2	I194.2	2	6	I194.3	6		<table border="1" style="width:100%; border-collapse: collapse;"> <tr><td style="width:10%;">+20/5.6</td><td style="width:10%;">+20-Q1:14</td></tr> <tr><td>+20/5.6</td><td>+20-K55:14</td></tr> <tr><td>+20/5.7</td><td>+20-K56:14</td></tr> <tr><td>+20/5.8</td><td>+20-K58:24</td></tr> </table>	+20/5.6	+20-Q1:14	+20/5.6	+20-K55:14	+20/5.7	+20-K56:14	+20/5.8	+20-K58:24	<table border="1" style="width:100%; border-collapse: collapse;"> <tr><td style="width:100%;">Travel drives main contactors ON</td></tr> <tr><td>Travel drives frequency converter is ON</td></tr> <tr><td>Travel drives frequency converter no failure</td></tr> <tr><td>Travel drives brakes thermistor brake resistor no failure</td></tr> </table>	Travel drives main contactors ON	Travel drives frequency converter is ON	Travel drives frequency converter no failure	Travel drives brakes thermistor brake resistor no failure
I194.0	1	5																									
I194.1	5	2																									
I194.2	2	6																									
I194.3	6																										
+20/5.6	+20-Q1:14																										
+20/5.6	+20-K55:14																										
+20/5.7	+20-K56:14																										
+20/5.8	+20-K58:24																										
Travel drives main contactors ON																											
Travel drives frequency converter is ON																											
Travel drives frequency converter no failure																											
Travel drives brakes thermistor brake resistor no failure																											

-A11	1194.4 ○ <u>1</u>	+.20/6.0	+.20-K61:14	Travel drive way end absolute right
	1194.5 ○ <u>5</u>	+.20/6.1	+.20-K62:14	Travel drive way end absolute left
	1194.6 ○ <u>2</u>	+.20/6.2	+.20-K63:14	Travel drive way end right
	1194.7 ○ <u>6</u>	+.20/6.3	+.20-K64:14	Travel drive way end left
-A12	1195.0 ○ <u>1</u>	+.20/6.4	+.20-K65:14	Set point pile 1
	1195.1 ○ <u>5</u>	+.20/6.5		Spare
	1195.2 ○ <u>2</u>	+.20/6.6	+.20-K51:24	Travel drive A-side Thermistor interrupt
	1195.3 ○ <u>6</u>	+.20/6.7	+.20-K52:24	Travel drive B-side thermistor interrupt
-A13	Q190.0 ○ <u>1</u>	+.01/5.3	+.01-K01:A1	Main power switch ON
	Q190.1 ○ <u>5</u>	+.09/7.1	+.09-K06:A1	EMG stop-relais reset
	Q190.2 ○ <u>2</u>	+.09/7.2	+.09-S2:x1	Signallamp Control ON
	Q190.3 ○ <u>6</u>	+.09/7.3	+.09-S3:x1	Signallamp Control OFF
-A14	Q190.4 ○ <u>1</u>	+.09/7.4	+.09-H2:x1	Signallamp Automatic mode ON
	Q190.5 ○ <u>5</u>	+.09/7.5	+.09-H1:x1	Centralized fault indication
	Q190.6 ○ <u>2</u>	+.09/7.6	+.09-S5:x1	Signallamp Reset
	Q190.7 ○ <u>6</u>	+.02/4.5	+.02-K01:A1	Control voltage 230V AC ON
-A15	Q191.0 ○ <u>1</u>	+.20/4.5	+.20-S31:x1	Signallamp Travel drive right ON
	Q191.1 ○ <u>5</u>	+.20/4.6	+.20-S32:x1	Signallamp Travel drive left ON
	Q191.2 ○ <u>2</u>	+.20/7.1	+.20-K01:A1	Travel drives main contactors ON
	Q191.3 ○ <u>6</u>	+.20/7.2	+.20-K31:A1	Travel drives frequency converter right direction ON
-A16	Q191.4 ○ <u>1</u>	+.20/7.3	+.20-K32:A1	Travel drives frequency converter left direction ON
	Q191.5 ○ <u>5</u>	+.20/8.5	+CK.20-B31:5	Nulljustage Resatron
	Q191.6 ○ <u>2</u>	+.20/7.4	+.20-K33:A1	Reset safety switch
	Q191.7 ○ <u>6</u>			

-A17	PIW240 ○ <u>1</u>	+20/7.5	+.20-G1:12	Travel speed from frequency converter actual value		
	CH0 ○ <u>2</u>	+20/7.5				
	OL+ ○ <u>3</u>	+20/7.6				
	OM ○ <u>4</u>	+20/7.6				
	PIW242 ○ <u>5</u>	+20/10.3	+.20-A01:5+		Material detection forward	
	CH1 ○ <u>6</u>	+20/10.3				
	1L+ ○ <u>7</u>	+20/10.4				
	1M ○ <u>8</u>	+20/10.4				
-A18	PIW244 ○ <u>1</u>	+20/10.7	+.20-A02:5+	Material detection reverse		
	CH2 ○ <u>2</u>	+20/10.7				
	2L+ ○ <u>3</u>	+20/10.8				
	2M ○ <u>4</u>	+20/10.8				
	PIW246 ○ <u>5</u>	+20/11.3	+.20-A03:5+		Frame detection forward	
	CH3 ○ <u>6</u>	+20/11.3				
	3L+ ○ <u>7</u>	+20/11.4				
	3M ○ <u>8</u>	+20/11.4				
-A19	PIW248 ○ <u>1</u>	+20/11.7	+.20-A04:5+	Frame detection reverse		
	CH4 ○ <u>2</u>	+20/11.7				
	4L+ ○ <u>3</u>	+20/11.8				
	4M ○ <u>4</u>	+20/11.8				
	PIW250 ○ <u>5</u>					
	CH5 ○ <u>6</u>					
	5L+ ○ <u>7</u>					
	5M ○ <u>8</u>					
	-A20	PQW240 ○ <u>1</u>	+20/7.7		+.20-G1:3	Travel speed to frequency converter setpoint value
		○ <u>2</u>				
		CH0 ○ <u>3</u>				
		○ <u>4</u>				
PQW242 ○ <u>5</u>						
○ <u>6</u>						
CH1 ○ <u>7</u>						
○ <u>8</u>						
-A21	SSI1 ○ <u>1</u>	+20/8.3		Travel drive position		
	SSI2 ○ <u>2</u>	+20/8.1				
	SSI3 ○ <u>3</u>	+20/8.1				
	SSI4 ○ <u>4</u>	+20/8.2				
	SSI5 ○ <u>5</u>	+20/8.3				
	SSI6 ○ <u>6</u>					
	SSI7 ○ <u>7</u>					
	SSI8 ○ <u>8</u>	+20/8.2				

Date	20.10.2010	Tripper car 523 TR 01		ET200S	20.230	= 523TR01
Ed.	Schmidt				28/04/2010	+ MC1.05
Appr	Dauterstedt				12345	Page 6 of 6
Modification	Date	Name	Original	Replacement of	Replaced by	034

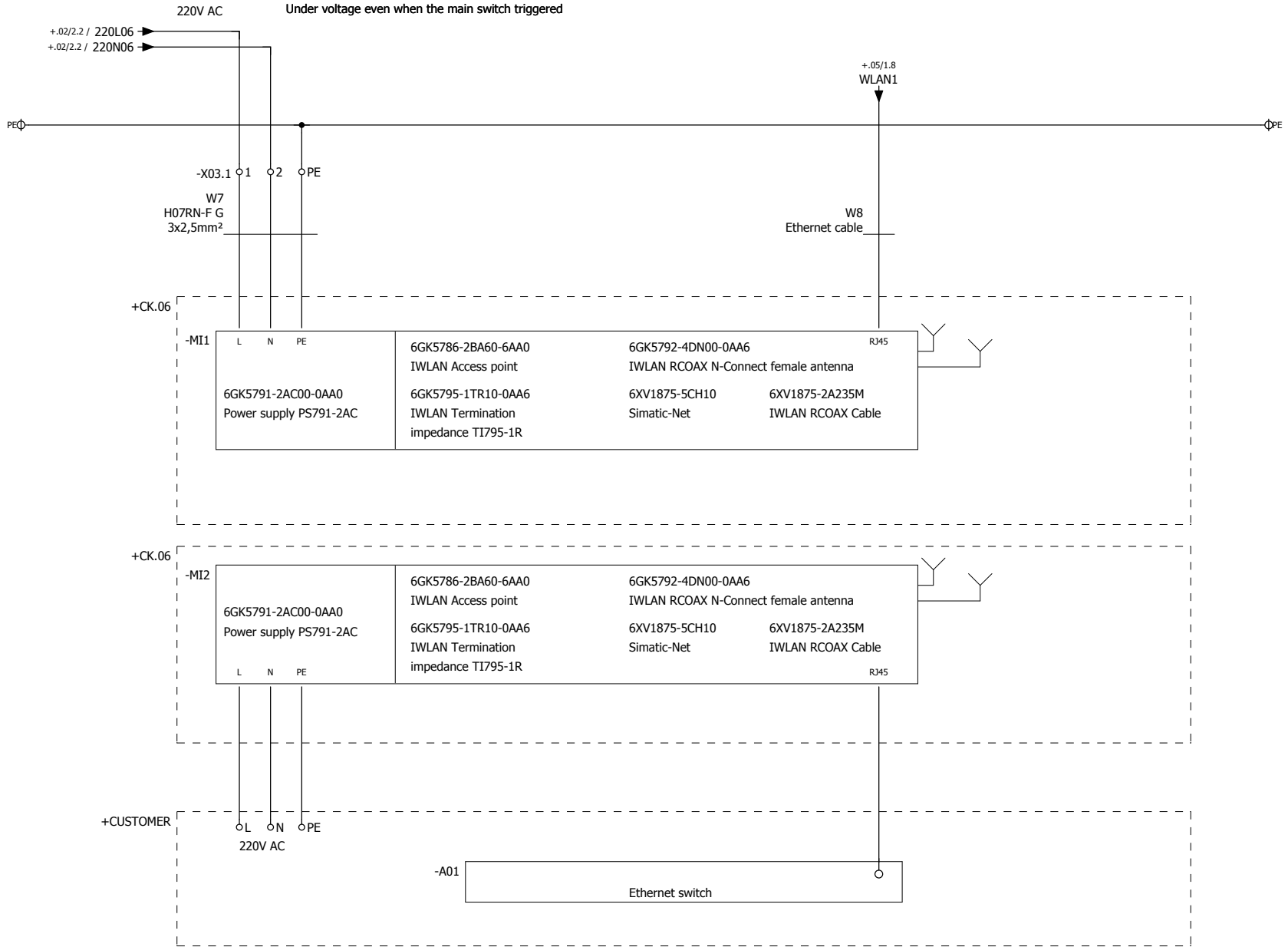

Modification	Date	Name	Original	Replacement of	Replaced by		Wlan	20.230	= 523TR01
								28/04/2010	+ MC1.06
								12345	Page 1 of 1
									035

Tripper car 523 TR 01  
Tonasa

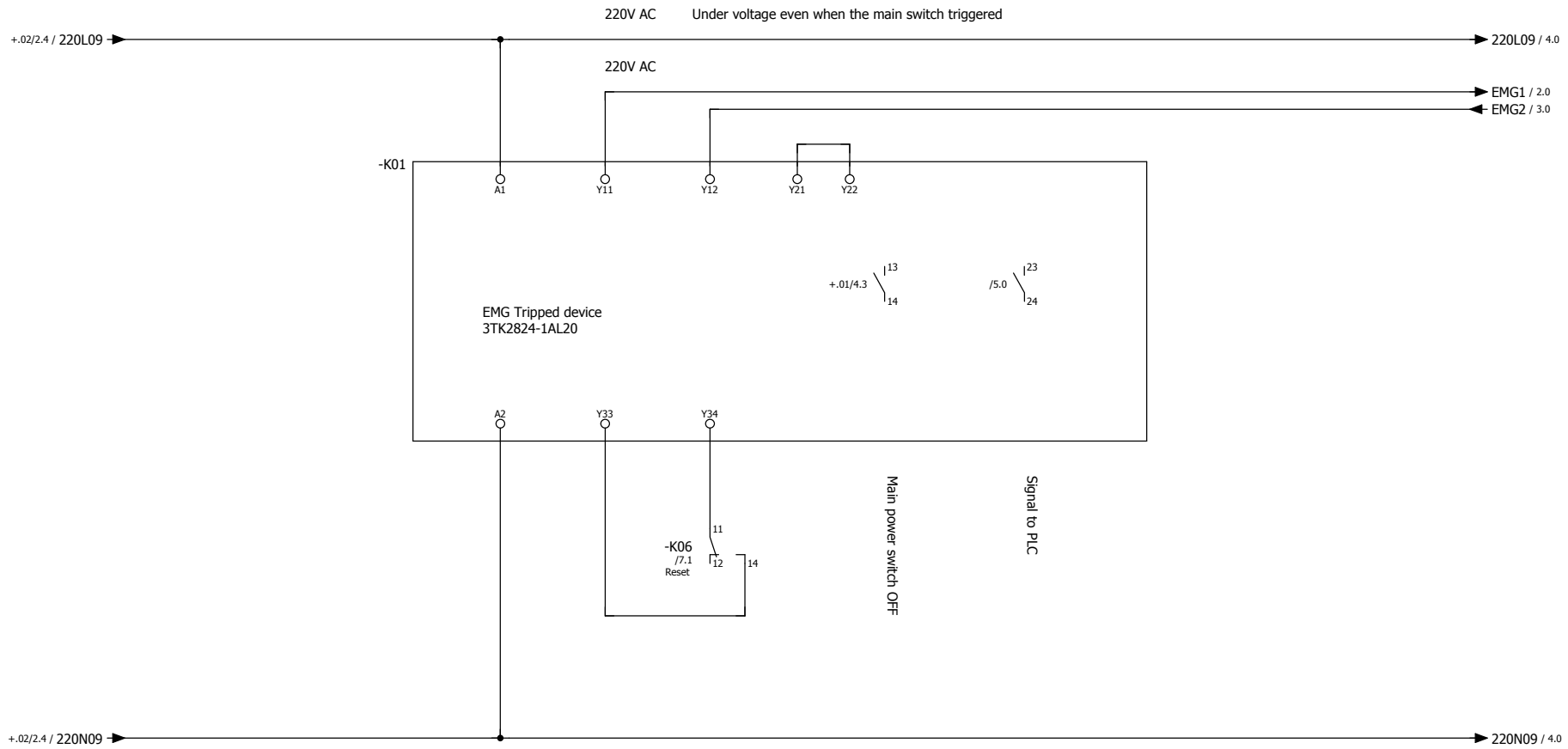

+06/1

			Date	20.10.2010	Tripper car 523 TR 01		EMERGENCY STOP safety switching device	20.230	= 523TR01
		Ed.	Schmidt	28/04/2010				+ MC1.09	
Modification	Date	Name	Original	Replacement of				Replaced by	12345
									036

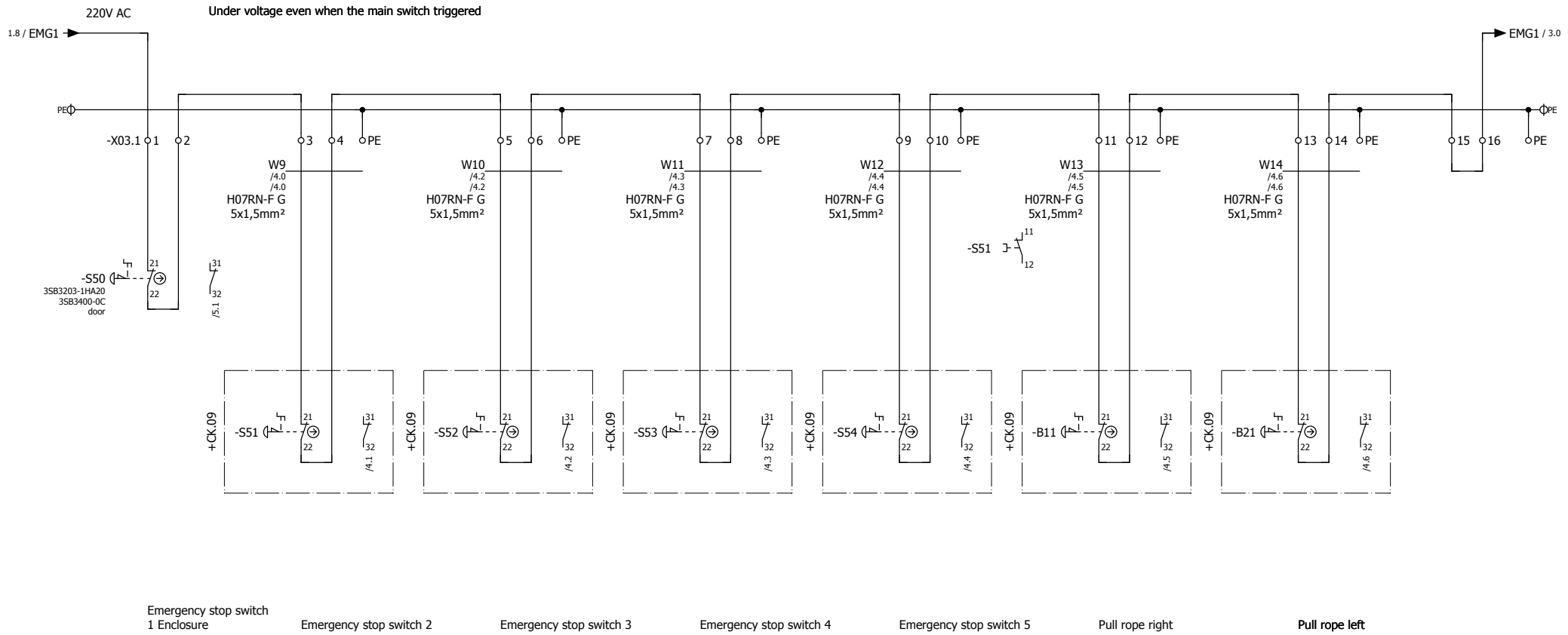

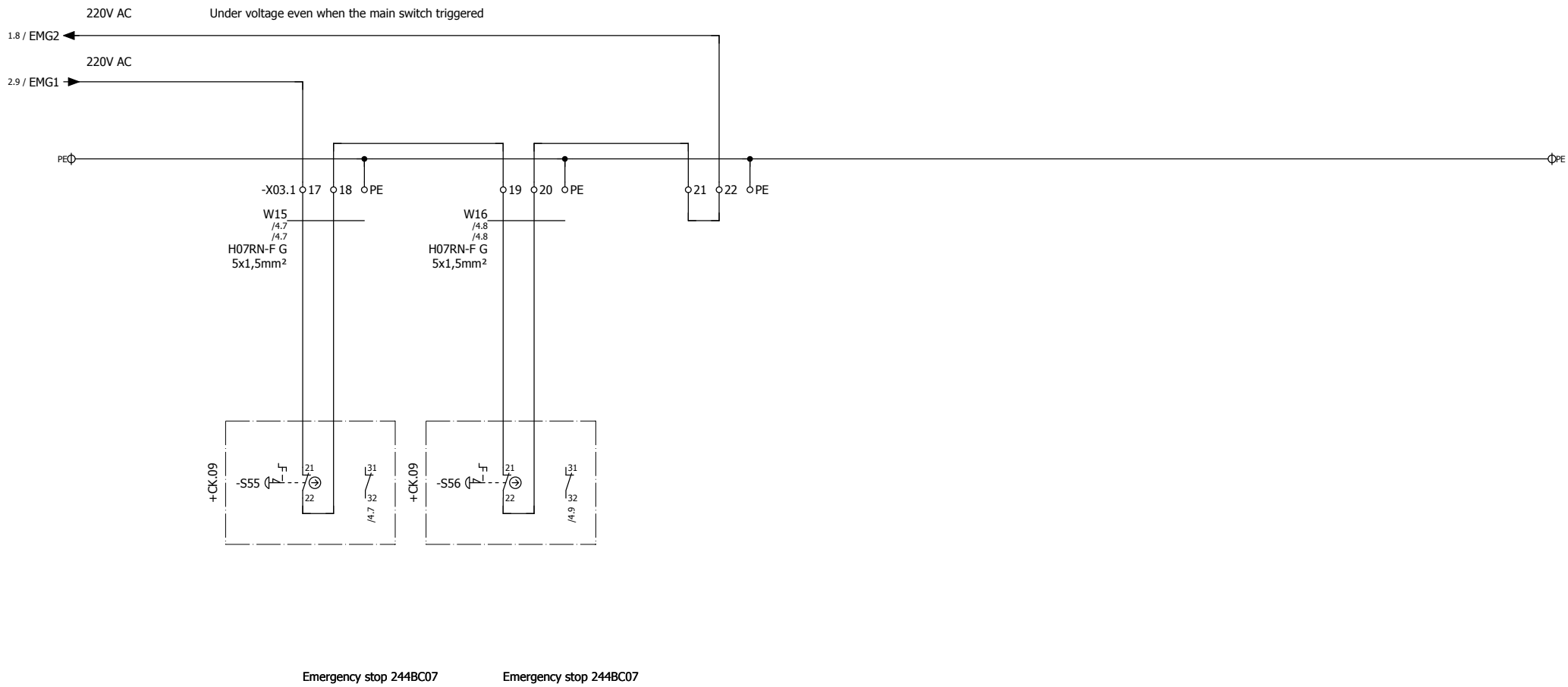

			Date	20.10.2010	Tripper car 523 TR 01 Tonasa		Emergency stop switch		20.230	= 523TR01
			Ed.	Schmidt					28/04/2010	+ MC1.09
			Appr	Dauterstedt					12345	Page 3 of 7
Modification	Date	Name	Original	Replacement of	Replaced by					038

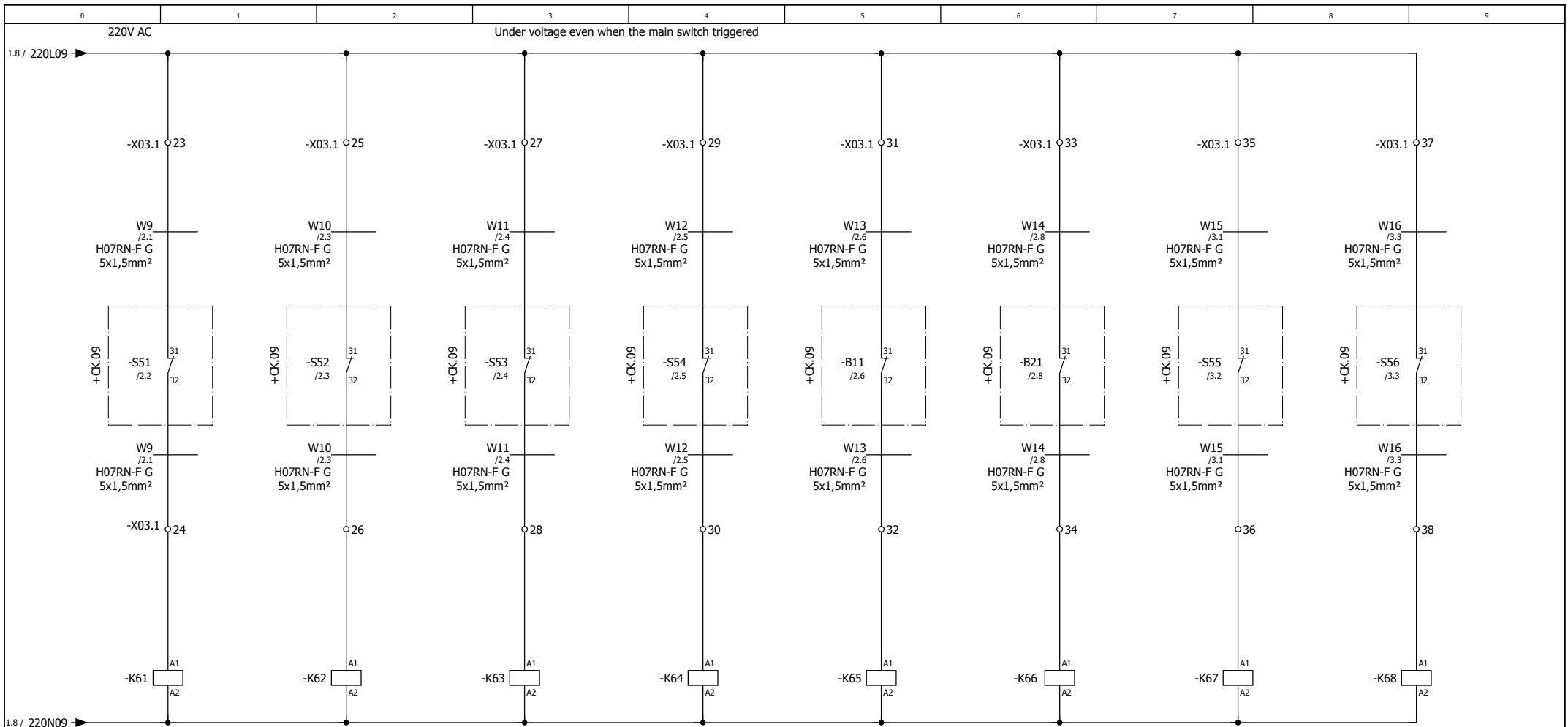

Emergency stop switch 2      Emergency stop switch 3      Emergency stop switch 4      Emergency stop switch 5      Pull rope right      Pull rope left      Emergency stop 244BC07      Emergency stop 244BC07

SIELZS:RT44T30 14	SIELZS:RT44T30 14	SIELZS:RT44T30 14	SIELZS:RT44T30 14	SIELZS:RT44T30 14	SIELZS:RT44T30 14	SIELZS:RT44T30 14	SIELZS:RT44T30 14
12 / 11 / 5.2	12 / 11 / 5.3	12 / 11 / 5.4	12 / 11 / 5.5	12 / 11 / 5.6	12 / 11 / 5.7	12 / 11 / 5.8	12 / 11 / 5.9
24	24	24	24	24	24	24	24
22 / 21	22 / 21	22 / 21	22 / 21	22 / 21	22 / 21	22 / 21	22 / 21

Date	20.10.2010	Tripper car 523 TR 01			Emergency stop switch	20.230	= 523TR01
Ed.	Schmidt	Tonasa				28/04/2010	+ MC1.09
Appr	Dauterstedt	Original	Replacement of	Replaced by		12345	Page 4 of 7
Modification	Date	Name					939

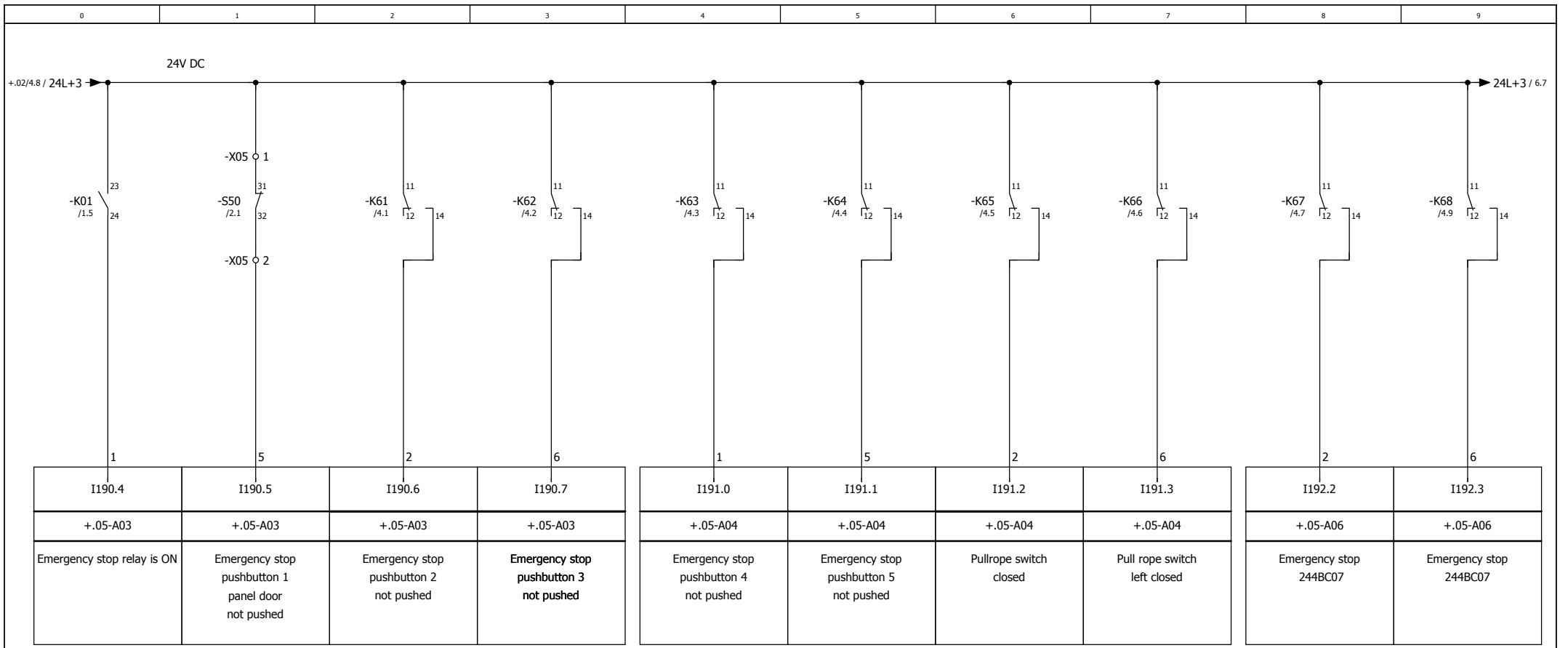

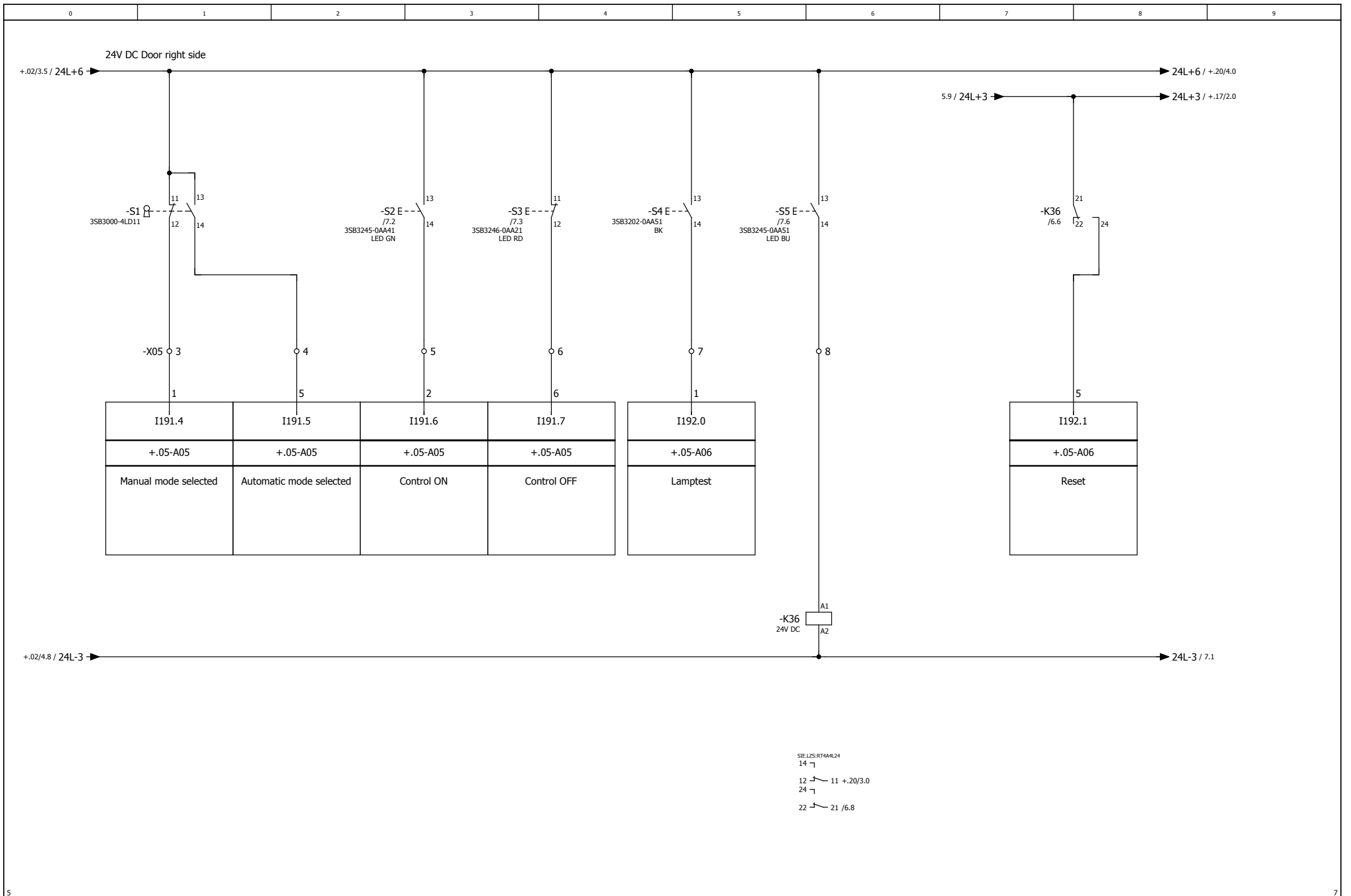

			Date	20.10.2010	Tripper car 523 TR 01 Tonasa	<b>SCHADE</b> AUMUND GROUP	Digital inputs / outputs		20.230	= 523TR01
			Ed.	Schmidt					28/04/2010	+ MC1.09
			Appr	Dauterstedt					12345	Page 6 of 7
Modification	Date	Name	Original		Replacement of	Replaced by				041

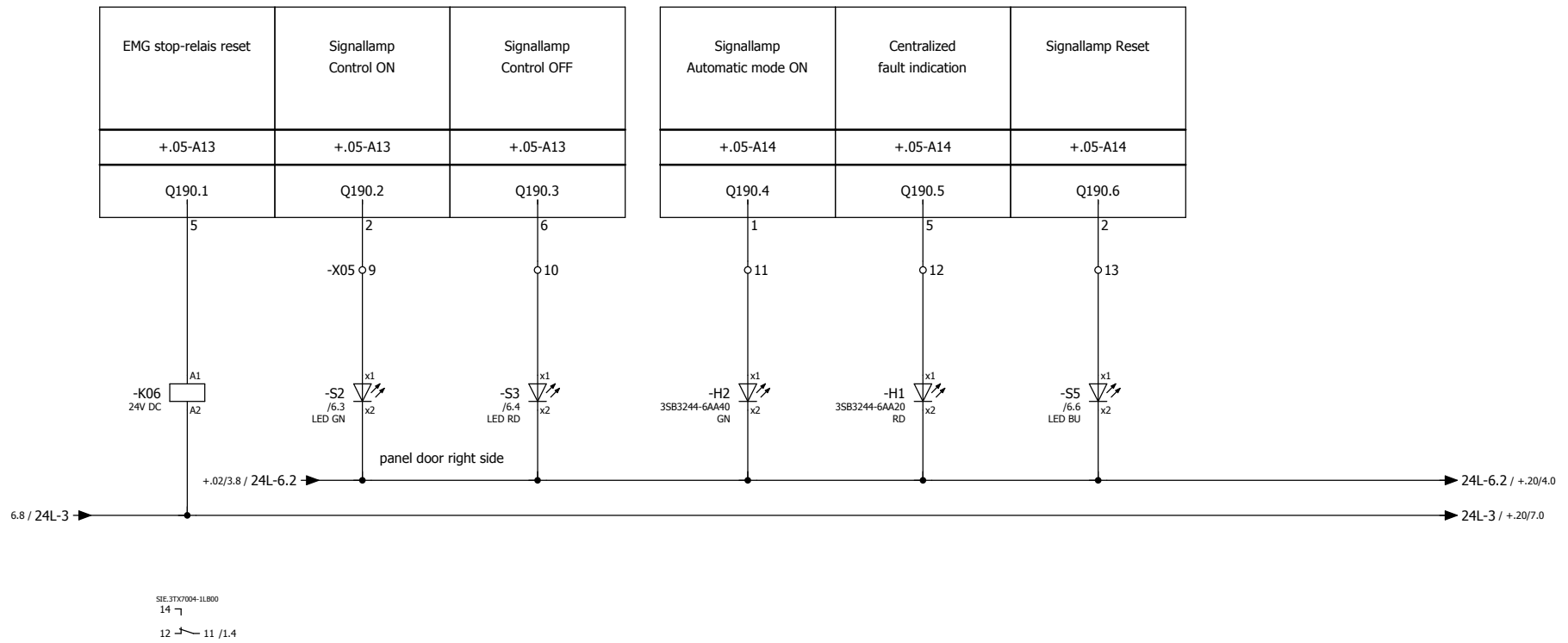

			Date	20.10.2010	<b>Trippler car 523 TR 01</b> <b>Tonasa</b>		Digital inputs / outputs	20.230	= 523TR01
			Ed.	Schmidt				28/04/2010	+ MC1.09
			Appr	Dauterstedt				12345	Page 7 of 7
Modification	Date	Name	Original	Replacement of	Replaced by				042

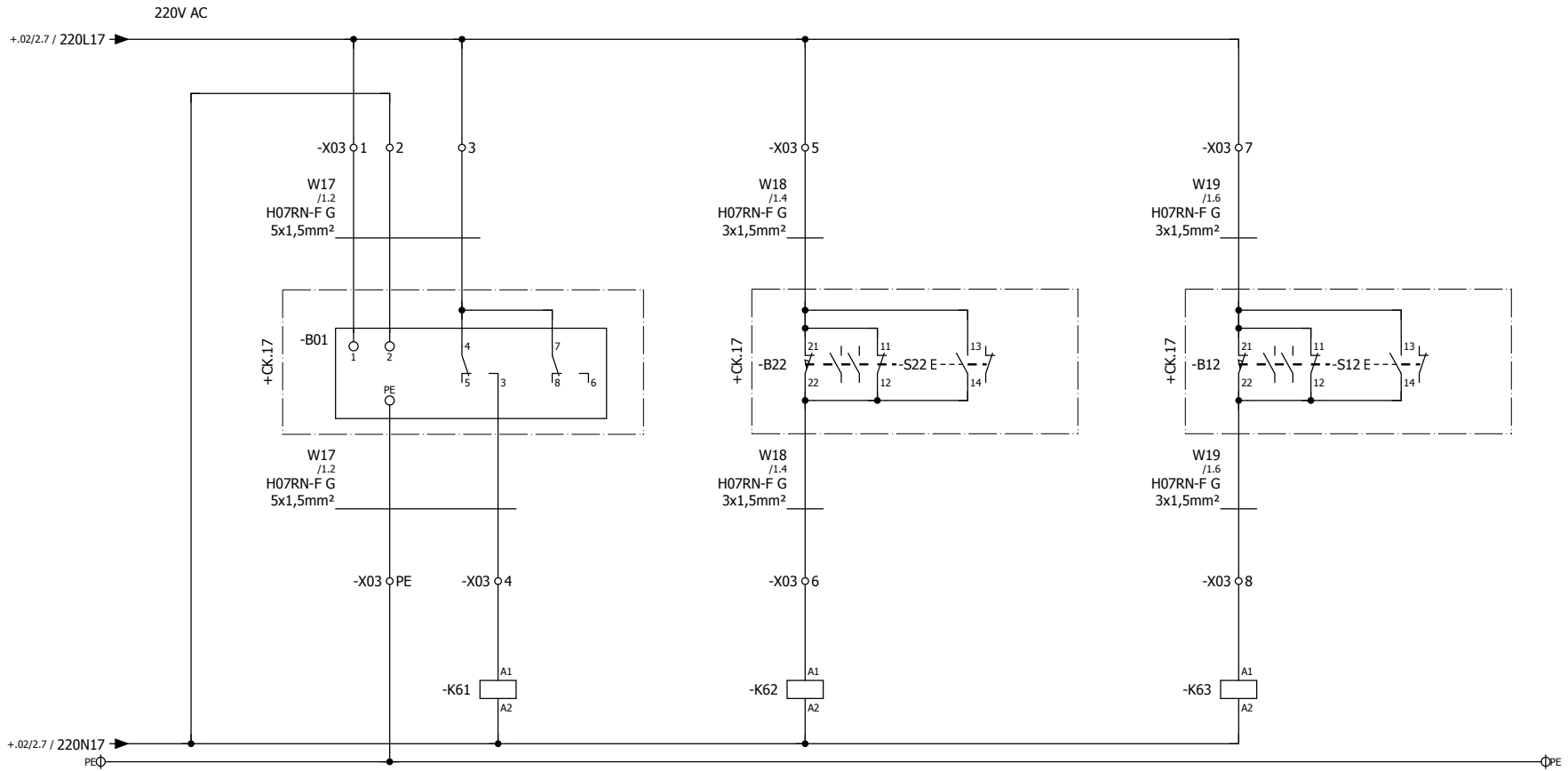

Chute overfiled

Misalignment left

Misalignment right

SIELZS:RT44AT30  
14 7  
12 11 /2.1  
24 7  
22 21

SIELZS:RT44AT30  
14 7  
12 11 /2.2  
24 7  
22 21

SIELZS:RT44AT30  
14 7  
12 11 /2.3  
24 7  
22 21

			Date	20.10.2010	Tripper car 523 TR 01 Tonasa		Tripper belt conveyor 523BC02	20.230	= 523TR01
		Ed.	Schmidt	28/04/2010				+ MC1.17	
Modification	Date	Name	Original	Replacement of				Replaced by	12345
								043	

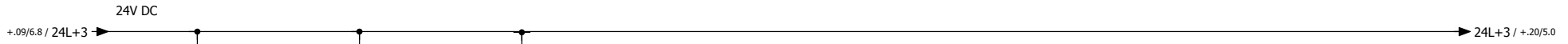

-K61  
/1.3

11

12

14

1

I192.4

+ .05-A07

Chute overfiled

-K62  
/1.4

11

12

14

5

I192.5

+ .05-A07

Misalignment left

-K63  
/1.6

11

12

14

2

I192.6

+ .05-A07

Misalignment right

			Date	20.10.2010	Tripper car 523 TR 01	<b>SCHADE</b> AUMUND GROUP	Tripper belt conveyor 523BC02	20.230	= 523TR01
			Ed.	Schmidt	Tonasa			28/04/2010	+ MC1.17
			Appr	Dauterstedt				12345	Page 2 of 2
Modification	Date	Name	Original		Replacement of	Replaced by			044

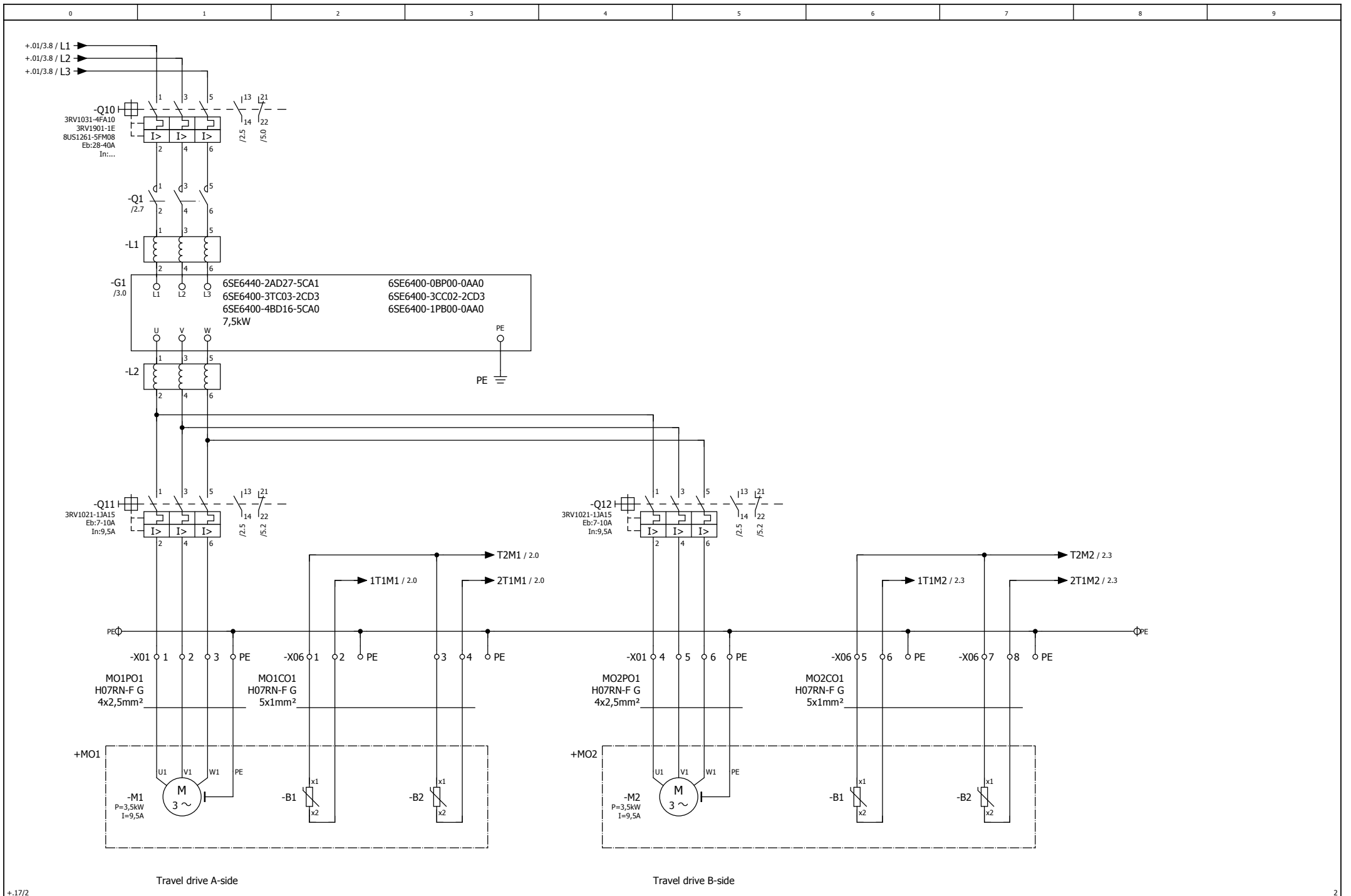

+17/2

		Date	20.10.2010	Tripper car 523 TR 01			Travel drive		20.230	= 523TR01
		Ed.	Schmidt	Tonasa			28/04/2010	+ MC1.20		
		Appr	Dauterstedt				12345	Page 1 of 11		
Modification	Date	Name	Original	Replacement of	Replaced by					045

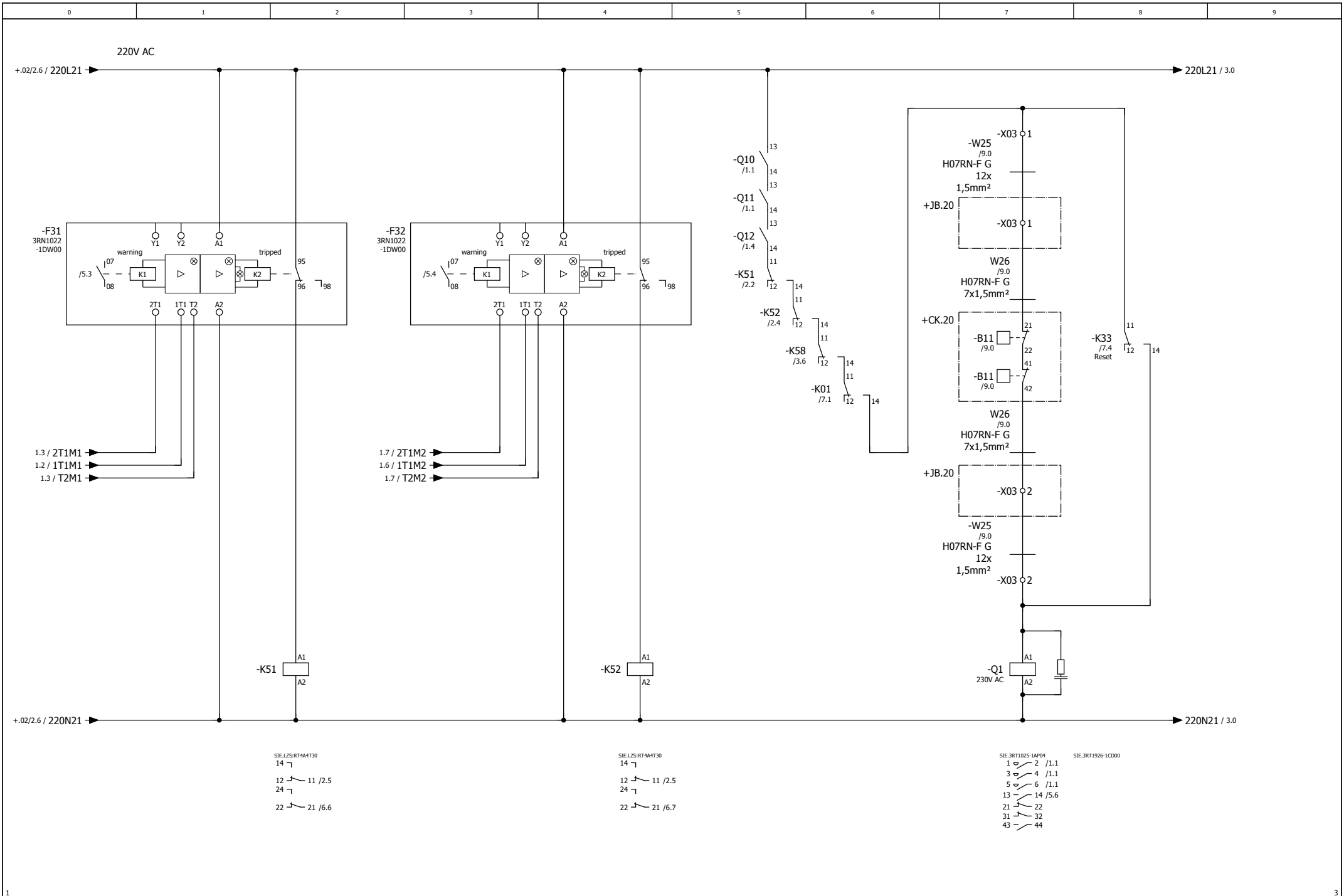

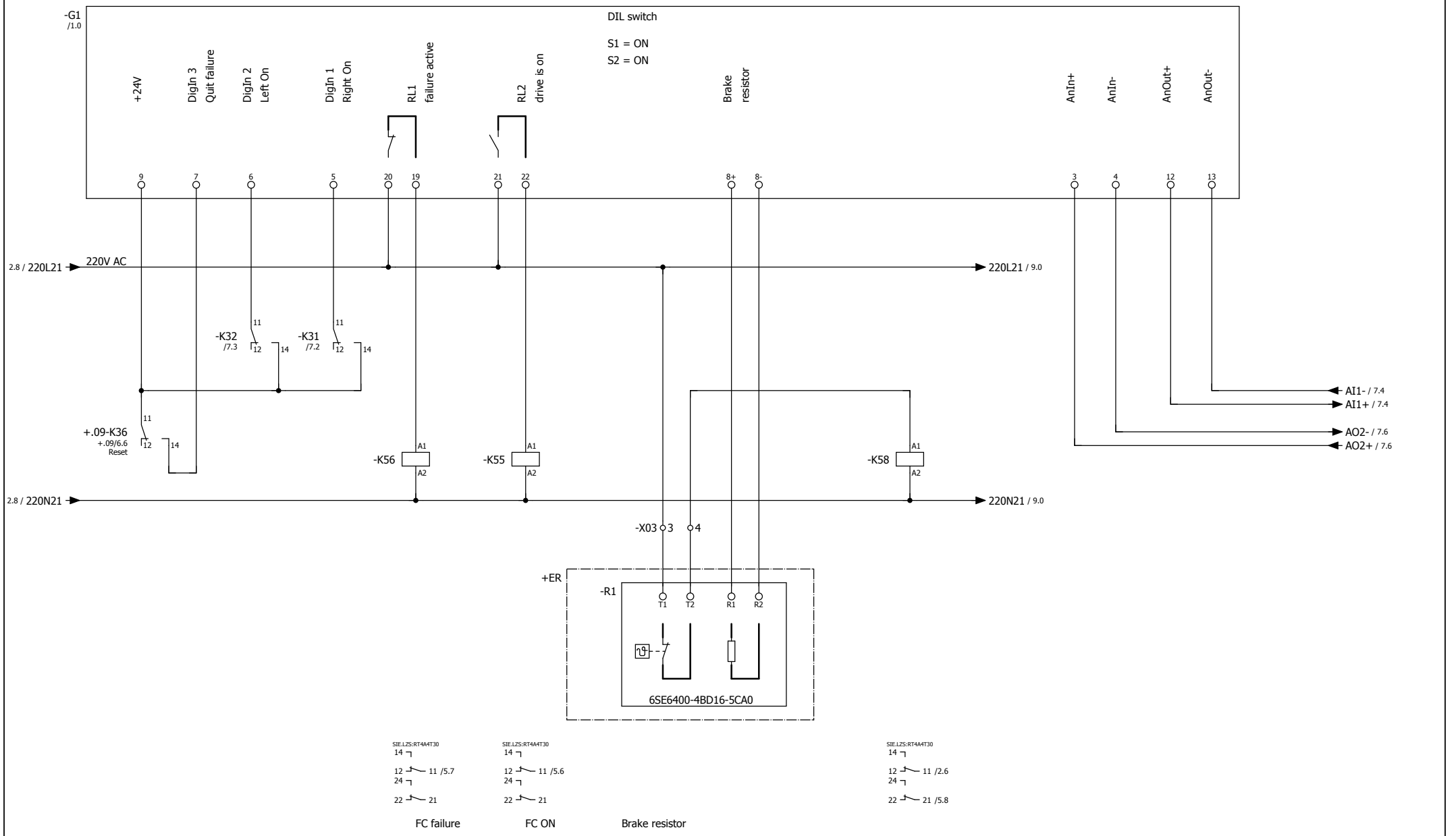

				Date	20.10.2010	Tripper car 523 TR 01			Travel drive		20.230 = 523TR01	
				Ed.	Schmidt	Tonasa			28/04/2010 + MC1.20			
				Appr	Dauterstedt				12345		Page 3 of 11	
Modification	Date	Name	Original	Replacement of	Replaced by							047

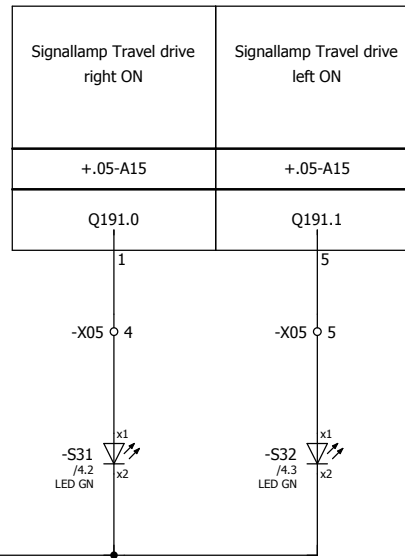
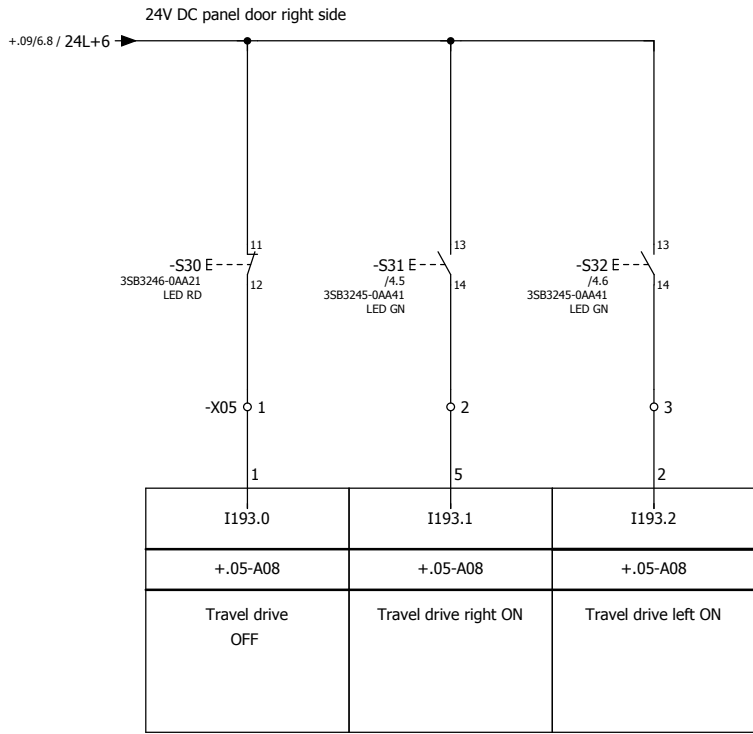

+ .09/7.8 / 24L-6.2

panel door right side

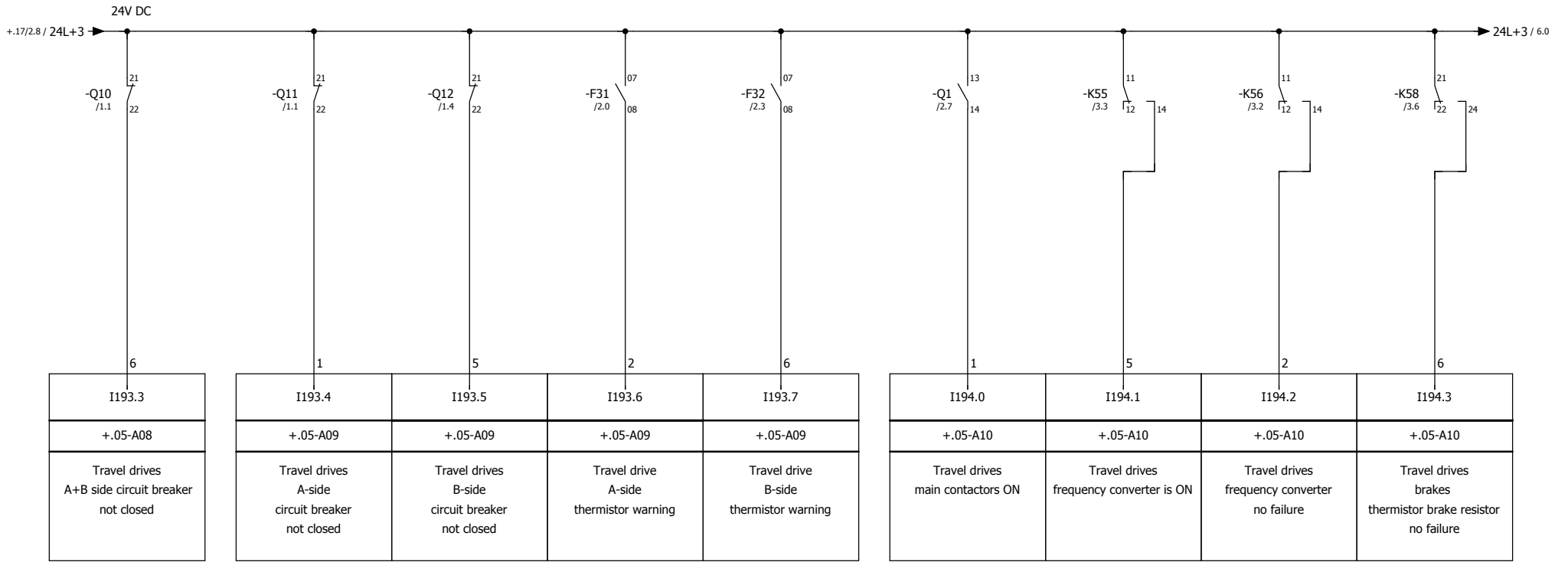

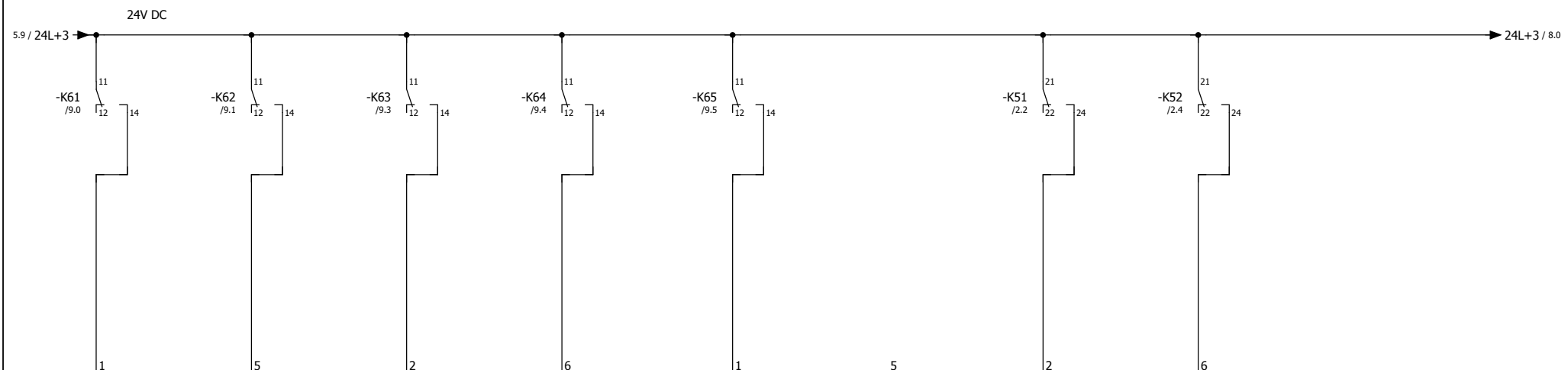

I194.4	I194.5	I194.6	I194.7	I195.0	I195.1	I195.2	I195.3
+.05-A11	+.05-A11	+.05-A11	+.05-A11	+.05-A12	+.05-A12	+.05-A12	+.05-A12
Travel drive way end absolute right	Travel drive way end absolute left	Travel drive way end right	Travel drive way end left	Set point pile 1	Spare	Travel drive A-side Thermistor interrupt	Travel drive B-side thermistor interrupt

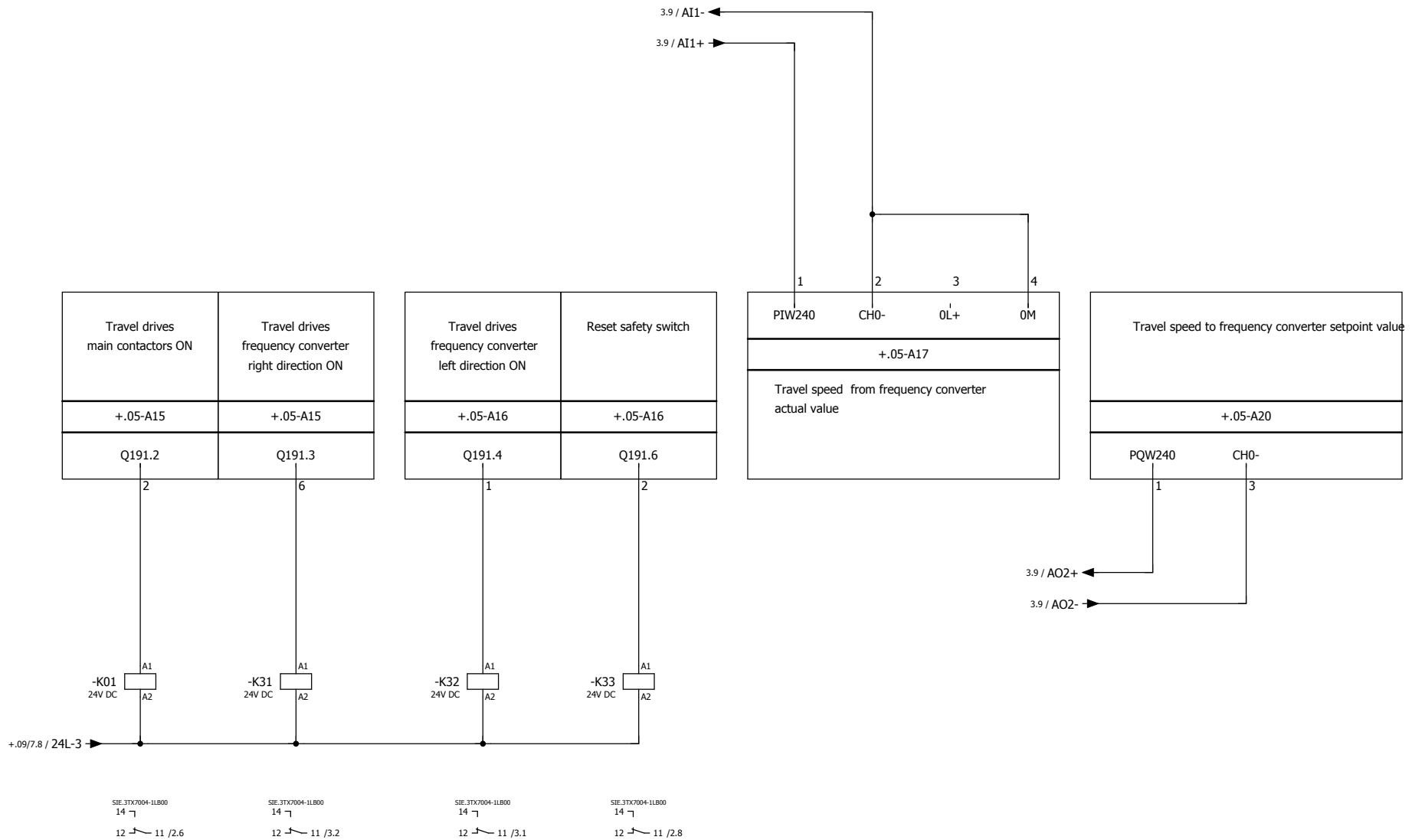

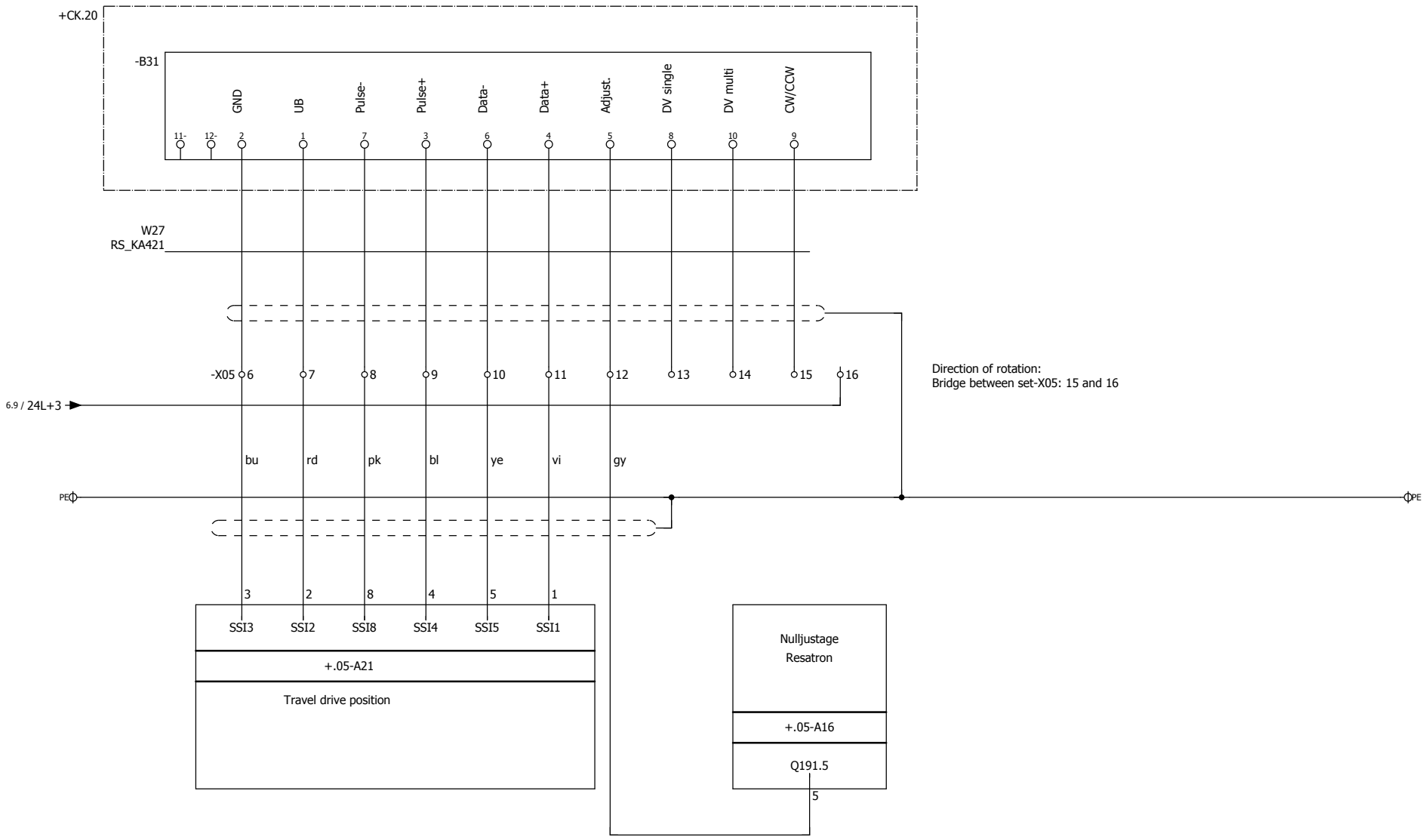

			Date	20.10.2010	<b>Tripper car 523 TR 01</b> <b>Tonasa</b>		Travel drive		20.230	= 523TR01
			Ed.	Schmidt					28/04/2010	+ MC1.20
			Appr	Dauterstedt					12345	Page 8 of 11
Modification	Date	Name	Original	Replacement of	Replaced by					052

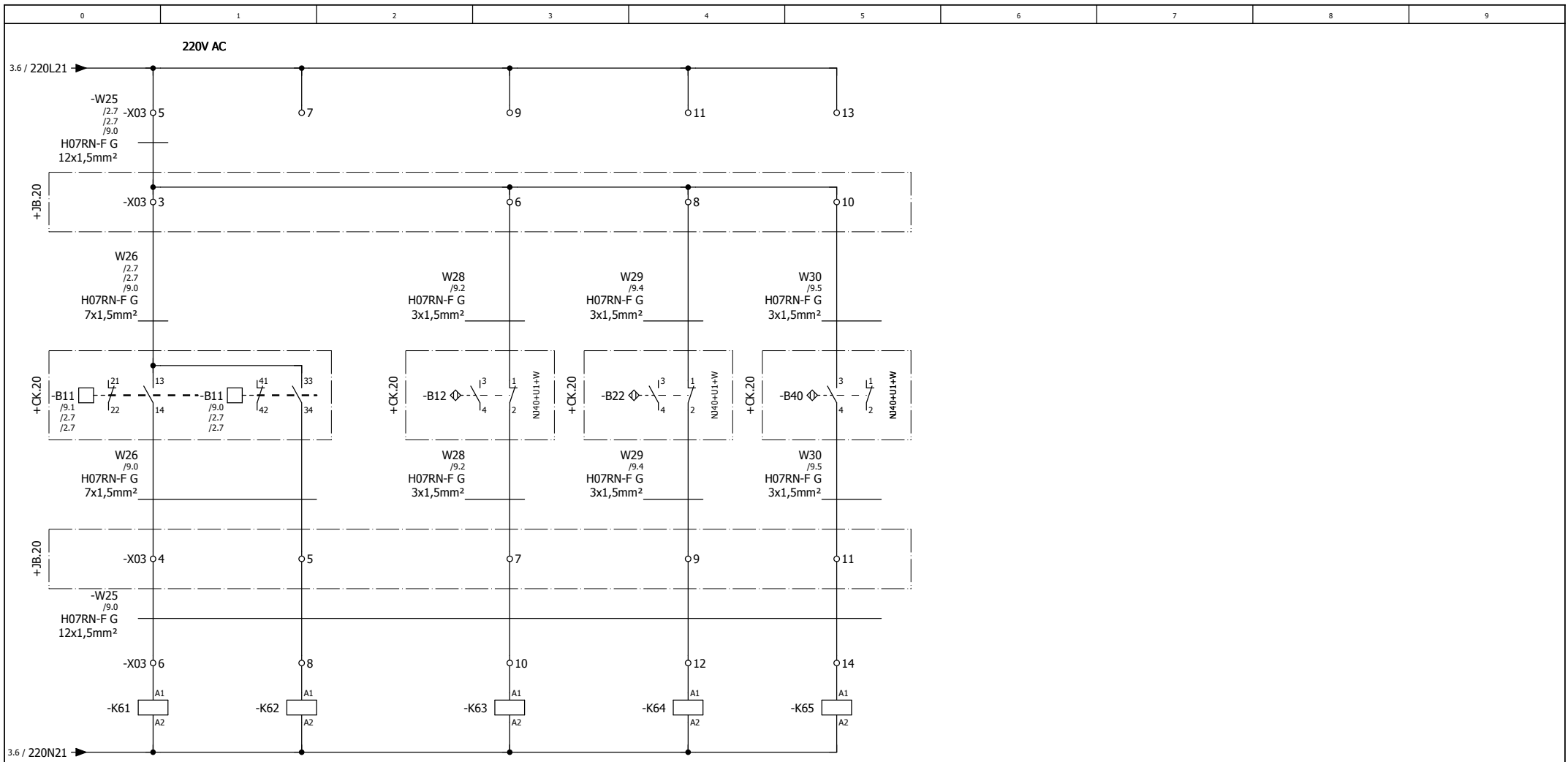

Travel drive way  
end absolute right

Travel drive way  
end absolute left

Travel drive way end right

Travel drive way end left

Set point pile 1

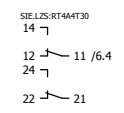
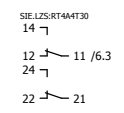
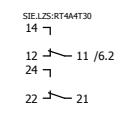
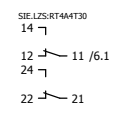
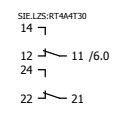

		Date	20.10.2010	<b>Tripper car 523 TR 01</b> <b>Tonasa</b>		Travel drive	20.230	= 523TR01
		Ed.	Schmidt				28/04/2010	+ MC1.20
		Appr	Dauterstedt				12345	Page 9 of 11
Modification	Date	Name	Original	Replacement of	Replaced by			053

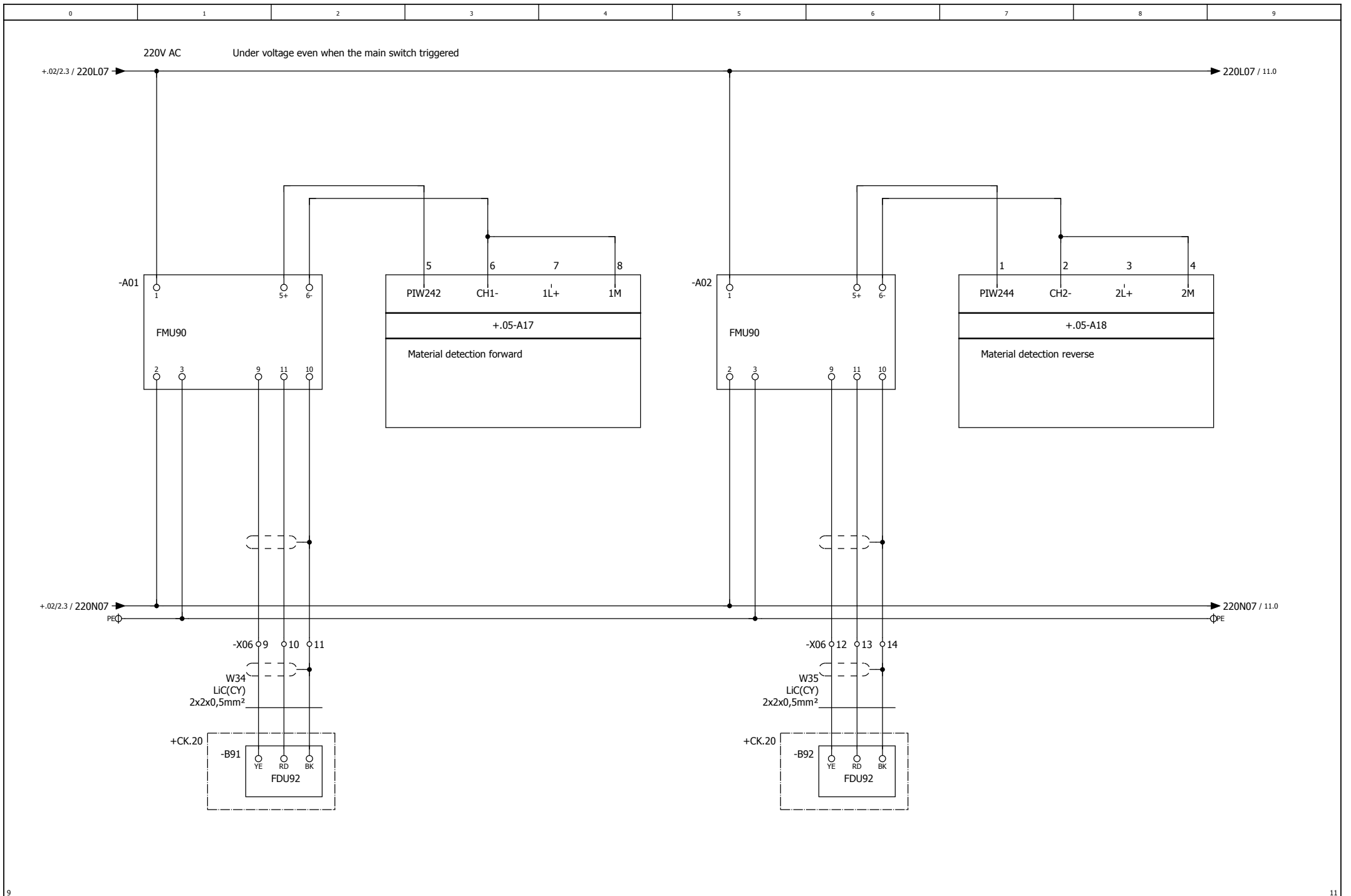

220V AC Under voltage even when the main switch triggered

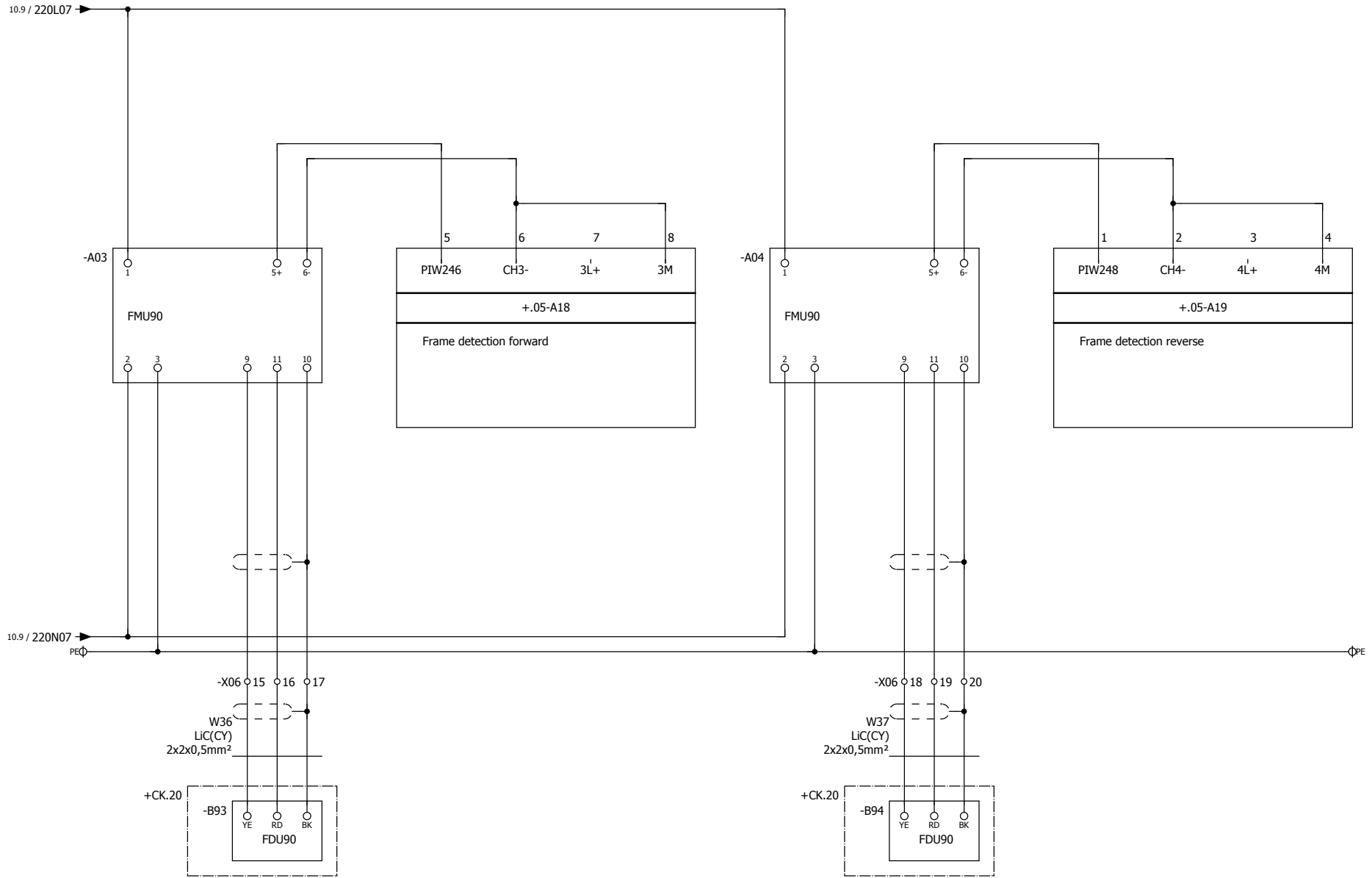

			Date	20.10.2010	Tripper car 523 TR 01 Tonasa		Travel drive	20.230	= 523TR01
			Ed.	Schmidt				28/04/2010	+ MC1.20
			Appr	Dauterstedt				12345	Page 11 of 11
Modification	Date	Name	Original	Replacement of	Replaced by				055

# Parts list

Schade\_001

device tag	Quantity	designation	supplier	part number
=523TR01+MC1.01-A1	1	Tripping delay	Siemens	SIE.3TX4701-0AN1
=523TR01+MC1.01-K01	1	Coupling relay	Siemens	SIE.3TX7004-1LB00
=523TR01+MC1.01-P1	1	Voltmeter 500V	Pötter	POT.EQ72 500V
=523TR01+MC1.01-P2	1	Amperemeter 100/5A	Pötter	POT.EQ72 100/5A
=523TR01+MC1.01-P3	1	Amperemeter 100/5A	Pötter	POT.EQ72 100/5A
=523TR01+MC1.01-P4	1	Amperemeter 100/5A	Pötter	POT.EQ72 100/5A
=523TR01+MC1.01-Q1	1	Circuit breaker 1,4-2A	Siemens	SIE.3RV1021-1BA10
=523TR01+MC1.01-Q1	1	Adapter busbar 60mm, S0, S00	Siemens	SIE.8US1251-5DM07
=523TR01+MC1.01-Q2	1	Circuit breaker 57-75A	Siemens	SIE.3RV1041-4KA10
=523TR01+MC1.01-Q2	1	Adapter busbar 40 and 60mm, for 3RV S3	Siemens	SIE.8US1111-4SM00
=523TR01+MC1.01-Q3	1	Circuit breaker VL 160N	Siemens	SIE.3VL2710-1DC33-2SB1
=523TR01+MC1.01-Q3	1	Rotary operating mechanism VL160X-251	Siemens	SIE.3VL9300-3HG05
=523TR01+MC1.01-Q3	1	Terminal cover VL160X, VL160, VL250	Siemens	SIE.3VL9300-8CB30
=523TR01+MC1.01-S1	1	Instr. selector sw. with 0-position	Moeller	MOE.T0-2-15920/EZ
=523TR01+MC1.01-T1	1	Current transformer 100/5A	MBS AG	MBS.MBS-7045
=523TR01+MC1.01-T2	1	Current transformer 100/5A	MBS AG	MBS.MBS-7045
=523TR01+MC1.01-T3	1	Current transformer 100/5A	MBS AG	MBS.MBS-7045
=523TR01+MC1.02-F1	1	Circuit breaker 6A/B	Siemens	SIE.5SY6106-6
=523TR01+MC1.02-F1	1	Auxiliary switch	Siemens	SIE.5ST3010
=523TR01+MC1.02-F2	1	Circuit breaker 6A/B	Siemens	SIE.5SY6106-6
=523TR01+MC1.02-F2	1	Auxiliary switch	Siemens	SIE.5ST3010
=523TR01+MC1.02-F3	1	Circuit breaker 6A/B	Siemens	SIE.5SY6106-6
=523TR01+MC1.02-F3	1	Auxiliary switch	Siemens	SIE.5ST3010
=523TR01+MC1.02-F4	1	Circuit breaker 6A/B	Siemens	SIE.5SY6106-6
=523TR01+MC1.02-F4	1	Auxiliary switch	Siemens	SIE.5ST3010
=523TR01+MC1.02-F5	1	Circuit breaker 6A/B	Siemens	SIE.5SY6106-6
=523TR01+MC1.02-F5	1	Auxiliary switch	Siemens	SIE.5ST3010
=523TR01+MC1.02-F11	1	Circuit breaker 6A/B	Siemens	SIE.5SY6106-6
=523TR01+MC1.02-F11	1	Auxiliary switch	Siemens	SIE.5ST3010
=523TR01+MC1.02-F12	1	Circuit breaker 6A/B	Siemens	SIE.5SY6106-6
=523TR01+MC1.02-F12	1	Auxiliary switch	Siemens	SIE.5ST3010
=523TR01+MC1.02-F20	1	Circuit breaker 20A/B	Siemens	SIE.5SY6220-6
=523TR01+MC1.02-F21	1	Circuit breaker 6A/C	Siemens	SIE.5SY6106-7
=523TR01+MC1.02-F21	1	Auxiliary switch	Siemens	SIE.5ST3010
=523TR01+MC1.02-F22	1	Circuit breaker 6A/B	Siemens	SIE.5SY6106-6
=523TR01+MC1.02-F22	1	Auxiliary switch	Siemens	SIE.5ST3010
=523TR01+MC1.02-F23	1	Circuit breaker 6A/B	Siemens	SIE.5SY6106-6
=523TR01+MC1.02-F24	1	Circuit breaker 6A/B	Siemens	SIE.5SY6106-6
=523TR01+MC1.02-F24	1	Auxiliary switch	Siemens	SIE.5ST3010
=523TR01+MC1.02-F25	1	Circuit breaker 6A/B	Siemens	SIE.5SY6106-6
=523TR01+MC1.02-F25	1	Auxiliary switch	Siemens	SIE.5ST3010
=523TR01+MC1.02-F26	1	Circuit breaker 6A/B	Siemens	SIE.5SY6106-6
=523TR01+MC1.02-F26	1	Auxiliary switch	Siemens	SIE.5ST3010
=523TR01+MC1.02-G1	1	SITOP Modular 24V / 20A	Siemens	SIE.6EP1436-3BA00
=523TR01+MC1.02-K01	1	SCHUETZ AC3:5,5KW/400V 1S DC24V	Siemens	SIE.3RT1017-1BB41
=523TR01+MC1.02-Q1	1	Circuit breaker 5,5-8A	Siemens	SIE.3RV1421-1HA10
=523TR01+MC1.02-Q1	1	Auxiliary switch	Siemens	SIE.3RV1901-1E
=523TR01+MC1.02-Q1	1	Adapter busbar 60mm, S0, S00	Siemens	SIE.8US1251-5DM07
=523TR01+MC1.02-Q2	1	Circuit breaker 9-12A	Siemens	SIE.3RV1011-1KA15
=523TR01+MC1.02-Q3	1	Circuit breaker 2,8-4A	Siemens	SIE.3RV1021-1EA15
=523TR01+MC1.02-Q3	1	Adapter busbar 60mm, S0, S00	Siemens	SIE.8US1251-5DM07
=523TR01+MC1.02-T1	1	Isolating Transformer 2,5kVA	Riedel	RIFED.0313-00002500
=523TR01+MC1.03-F1	1	Circuit breaker 10A/B	Siemens	SIE.5SY6110-6
=523TR01+MC1.03-F2	1	Circuit breaker 10A/B	Siemens	SIE.5SY6110-6
=523TR01+MC1.03-F3	1	Circuit breaker 6A/B	Siemens	SIE.5SY6106-6
=523TR01+MC1.03-F4	1	Circuit breaker 10A/B	Siemens	SIE.5SY6110-6

+MC1.20/11

1.a

Date	20.10.2010	<b>Tripper car 523 TR 01</b> <b>Tonasa</b>		Parts list : SIE.3TX4701-0AN1 - SIE.5SY6110-6	20.230	= 523TR01
Ed.	Schmidt				28/04/2010	+ STKL
Appr	Dauterstedt				12345	Page 1 of 1.c
Modification	Date	Name	Original	Replacement of	Replaced by	056

# Parts list

Schade\_001

device tag	Quantity	designation	supplier	part number
=523TR01+MC1.03-F5	1	Circuit breaker 16A/B	Siemens	SIE.5SY6116-6
=523TR01+MC1.03-K1	1	Remote control switch, 4NO, 230V AC	Siemens	SIE.5TT4103-0
=523TR01+MC1.03-Q1	1	Circuit breaker 57-75A	Siemens	SIE.3RV1041-4KA10
=523TR01+MC1.03-Q1	1		Siemens	SIE.8US111-4SM00
=523TR01+MC1.03-Q2	1	Circuit breaker 14-20A	Siemens	SIE.3RV1431-4BA10
=523TR01+MC1.03-Q2	1	Adapter busbar 60mm, for 3RV 52	Siemens	SIE.8US1261-5FM08
=523TR01+MC1.03-Q3	1	Circuit breaker 14-20A	Siemens	SIE.3RV1031-4BA10
=523TR01+MC1.03-Q3	1	Adapter busbar 60mm, for 3RV 52	Siemens	SIE.8US1261-5FM08
=523TR01+MC1.04-E01	1	Enclosure heater prot. cat. IP 40 therm. output 130 W, 230 V max. temperature range: +65°C +/-5°C	Rittal	RIT.3107000
=523TR01+MC1.04-F1	1	Circuit breaker 6A/B	Siemens	SIE.5SY6106-6
=523TR01+MC1.04-F2	1	Circuit breaker 4A/B	Siemens	SIE.5SY6104-6
=523TR01+MC1.04-F3	1	Circuit breaker 16A/B	Siemens	SIE.5SY6116-6
=523TR01+MC1.04-H1	1	Panel light	J. Richter Elektrotechnik	RICH.LL14-SK-R
=523TR01+MC1.04-H2	1	Panel light	J. Richter Elektrotechnik	RICH.LL14-SK-R
=523TR01+MC1.04-S01	1	Hygrostat	Rittal	RIT.3118000
=523TR01+MC1.04-XU1	1	Socket	Phoenix Contact	PHO.SD-D/SC/GY
=523TR01+MC1.05-A00	1	IM 151-1 STD	Siemens	SIE.6ES7151-1AA04-0AB0
=523TR01+MC1.05-A01	1	PM-E, DC 24V	Siemens	SIE.6ES7138-4CA01-0AA0
=523TR01+MC1.05-A02	1	4DI ST, DC 24V	Siemens	SIE.6ES7131-4BD01-0AA0
=523TR01+MC1.05-A03	1	4DI ST, DC 24V	Siemens	SIE.6ES7131-4BD01-0AA0
=523TR01+MC1.05-A04	1	4DI ST, DC 24V	Siemens	SIE.6ES7131-4BD01-0AA0
=523TR01+MC1.05-A05	1	4DI ST, DC 24V	Siemens	SIE.6ES7131-4BD01-0AA0
=523TR01+MC1.05-A06	1	4DI ST, DC 24V	Siemens	SIE.6ES7131-4BD01-0AA0
=523TR01+MC1.05-A07	1	4DI ST, DC 24V	Siemens	SIE.6ES7131-4BD01-0AA0
=523TR01+MC1.05-A08	1	4DI ST, DC 24V	Siemens	SIE.6ES7131-4BD01-0AA0
=523TR01+MC1.05-A09	1	4DI ST, DC 24V	Siemens	SIE.6ES7131-4BD01-0AA0
=523TR01+MC1.05-A10	1	4DI ST, DC 24V	Siemens	SIE.6ES7131-4BD01-0AA0
=523TR01+MC1.05-A11	1	4DI ST, DC 24V	Siemens	SIE.6ES7131-4BD01-0AA0
=523TR01+MC1.05-A12	1	4DI ST, DC 24V	Siemens	SIE.6ES7131-4BD01-0AA0
=523TR01+MC1.05-A13	1	1 SSI 25BIT/1MHZ	Siemens	SIE.6ES7138-4DB03-0AB0
=523TR01+MC1.05-A14	1	4DO ST, DC 24V, 0.5A	Siemens	SIE.6ES7132-4BD02-0AA0
=523TR01+MC1.05-A15	1	4DO ST, DC 24V, 0.5A	Siemens	SIE.6ES7132-4BD02-0AA0
=523TR01+MC1.05-A16	1	4DO ST, DC 24V, 0.5A	Siemens	SIE.6ES7132-4BD02-0AA0
=523TR01+MC1.05-A17	1	2AI STD I-4DMA, 4-20MA	Siemens	SIE.6ES7134-4GB11-0AB0
=523TR01+MC1.05-A18	1	2AO I, +/-20MA, 4-20MA, 12BIT	Siemens	SIE.6ES7135-4GB01-0AB0
=523TR01+MC1.05-A19	1	1 SSI 25BIT/1MHZ	Siemens	SIE.6ES7138-4DB03-0AB0
=523TR01+MC1.05-A20	1	1 SSI 25BIT/1MHZ	Siemens	SIE.6ES7138-4DB03-0AB0
=523TR01+MC1.05-A21	1	1 SSI 25BIT/1MHZ	Siemens	SIE.6ES7138-4DB03-0AB0
=523TR01+MC1.05-A30	1	SIMATIC S7-300, Load current supply	Siemens	SIE.6ES7307-1EA00-0AA0
=523TR01+MC1.05-A31	1	CPU 315-2 PN/DP	Siemens	SIE.6ES7315-2EH13-0AB0
=523TR01+MC1.05-A40	1	Ethernet switch 5 port	Weidmüller	WEI.IE-SW5-ECO
=523TR01+MC1.09-H1	1	KOMPLLEUCHTM.GLATT,LED 24V,RD,SCHRAUB.	Siemens	SIE.3SB3244-6AA20
=523TR01+MC1.09-H2	1	Signallamp, LED 24V, green	Siemens	SIE.3SB3244-6AA40
=523TR01+MC1.09-K01	1	SIRIUS SAFETY RELAY WITH RELAY RELEASE CIRCUITS (FK)	Siemens	SIE.3TK2824-1AL20
=523TR01+MC1.09-K06	1	Coupling relay	Siemens	SIE.3TX7004-1LB00
=523TR01+MC1.09-K36	1	relay	Siemens	SIE.LZS:RT4A4L24
=523TR01+MC1.09-K61	1	relay	Siemens	SIE.LZS:RT4A4T30
=523TR01+MC1.09-K62	1	relay	Siemens	SIE.LZS:RT4A4T30
=523TR01+MC1.09-K63	1	relay	Siemens	SIE.LZS:RT4A4T30
=523TR01+MC1.09-K64	1	relay	Siemens	SIE.LZS:RT4A4T30
=523TR01+MC1.09-K65	1	relay	Siemens	SIE.LZS:RT4A4T30
=523TR01+MC1.09-K66	1	relay	Siemens	SIE.LZS:RT4A4T30
=523TR01+MC1.09-K67	1	relay	Siemens	SIE.LZS:RT4A4T30
=523TR01+MC1.09-K68	1	relay	Siemens	SIE.LZS:RT4A4T30
=523TR01+MC1.09-S1	1	Code switch	Siemens	SIE.3SB3000-4LD11
=523TR01+MC1.09-S2	1	Illuminated pushbutton green	Siemens	SIE.3SB3245-0AA41

1

1.b

Date	20.10.2010	<b>Tripper car 523 TR 01</b> <b>Tonasa</b>		Parts list : SIE.5SY6116-6 - SIE.3SB3245-0AA41	20.230	= 523TR01
Ed.	Schmidt				28/04/2010	+ STKL
Appr	Dauterstedt				12345	Page 1.a of 1.c
Modification	Date	Name	Original	Replacement of	Replaced by	057

# Parts list

Schade\_001

device tag	Quantity	designation	supplier	part number
=523TR01+MC1.09-S3	1	Illuminated pushbutton red	Siemens	SIE.3SB3246-0AA21
=523TR01+MC1.09-S4	1	Pushbutton blue	Siemens	SIE.3SB3202-0AA51
=523TR01+MC1.09-S5	1	Illuminated pushbutton blue	Siemens	SIE.3SB3245-0AA51
=523TR01+MC1.09-S50	1	Emergency stop button	Siemens	SIE.3SB3203-1HA20
=523TR01+MC1.17-K61	1	relay	Siemens	SIE.LZS:RT4A4T30
=523TR01+MC1.17-K62	1	relay	Siemens	SIE.LZS:RT4A4T30
=523TR01+MC1.17-K63	1	relay	Siemens	SIE.LZS:RT4A4T30
=523TR01+MC1.20-A01	1	Transmitter	Endress & Hauser	EuH.PROSONICSFMU90
=523TR01+MC1.20-A02	1	Transmitter	Endress & Hauser	EuH.PROSONICSFMU90
=523TR01+MC1.20-A03	1	Transmitter	Endress & Hauser	EuH.PROSONICSFMU90
=523TR01+MC1.20-A04	1	Transmitter	Endress & Hauser	EuH.PROSONICSFMU90
=523TR01+MC1.20-F31	1	Motor protective relay	Siemens	SIE.3RN1022-1DW00
=523TR01+MC1.20-F32	1	Motor protective relay	Siemens	SIE.3RN1022-1DW00
=523TR01+MC1.20-G1	1	Micromaster 440 frequency converter 7,5KW	Siemens	SIE.6SE6440-2AD27-5CA1
=523TR01+MC1.20-G1	2	Micromaster 4 output reactor	Siemens	SIE.6SE6400-3TC03-2CD3
=523TR01+MC1.20-G1	1	Micromaster 4 basic operator panel	Siemens	SIE.6SE6400-0BP00-0AA0
=523TR01+MC1.20-G1	1	Micromaster 4 input reactor	Siemens	SIE.6SE6400-3CC02-2CD3
=523TR01+MC1.20-G1	1	Accessories for Micromaster	Siemens	SIE.6SE6400-1PB00-0AA0
=523TR01+MC1.20-K01	1	Coupling relay	Siemens	SIE.3TX7004-1LB00
=523TR01+MC1.20-K31	1	Coupling relay	Siemens	SIE.3TX7004-1LB00
=523TR01+MC1.20-K32	1	Coupling relay	Siemens	SIE.3TX7004-1LB00
=523TR01+MC1.20-K33	1	Coupling relay	Siemens	SIE.3TX7004-1LB00
=523TR01+MC1.20-K51	1	relay	Siemens	SIE.LZS:RT4A4T30
=523TR01+MC1.20-K52	1	relay	Siemens	SIE.LZS:RT4A4T30
=523TR01+MC1.20-K55	1	relay	Siemens	SIE.LZS:RT4A4T30
=523TR01+MC1.20-K56	1	relay	Siemens	SIE.LZS:RT4A4T30
=523TR01+MC1.20-K58	1	relay	Siemens	SIE.LZS:RT4A4T30
=523TR01+MC1.20-K61	1	relay	Siemens	SIE.LZS:RT4A4T30
=523TR01+MC1.20-K62	1	relay	Siemens	SIE.LZS:RT4A4T30
=523TR01+MC1.20-K63	1	relay	Siemens	SIE.LZS:RT4A4T30
=523TR01+MC1.20-K64	1	relay	Siemens	SIE.LZS:RT4A4T30
=523TR01+MC1.20-K65	1	relay	Siemens	SIE.LZS:RT4A4T30
=523TR01+MC1.20-Q1	1	Contactactor AC3:7,5KW/400V	Siemens	SIE.3RT1025-1AP04
=523TR01+MC1.20-Q1	1	RC-element, AC 127-240V, DC 150-240V	Siemens	SIE.3RT1926-1CD00
=523TR01+MC1.20-Q10	1	Circuit breaker 28-40A	Siemens	SIE.3RV1031-4FA10
=523TR01+MC1.20-Q10	1	Auxiliary switch	Siemens	SIE.3RV1901-1E
=523TR01+MC1.20-Q10	1	Adapter busbar 60mm, for 3RV S2	Siemens	SIE.8US1261-5FM08
=523TR01+MC1.20-Q11	1	Circuit breaker 7-10A	Siemens	SIE.3RV1021-1JA15
=523TR01+MC1.20-Q12	1	Circuit breaker 7-10A	Siemens	SIE.3RV1021-1JA15
=523TR01+MC1.20-S30	1	Illuminated pushbutton red	Siemens	SIE.3SB3246-0AA21
=523TR01+MC1.20-S31	1	Illuminated pushbutton green	Siemens	SIE.3SB3245-0AA41
=523TR01+MC1.20-S32	1	Illuminated pushbutton green	Siemens	SIE.3SB3245-0AA41
=523TR01+DS1-Q1	1	Disconnecting switch 125A	Siemens	SIE.3KL5230-1GB01
=523TR01+DS1-Q1	1	Terminal cover	Siemens	SIE.3KX3552-3DA01
=523TR01+DS1-Q1	1	Terminal cover	Siemens	SIE.3KX3527-3AA
=523TR01+CK.06-M11	1	Power supply PS791-2AC	Siemens	SIE.6GK5791-2AC00-0AA0
=523TR01+CK.06-M11	1	IWLAN access point SCALANCE W786-2RR	Siemens	SIE.6GK5786-2BA60-6AA0
=523TR01+CK.06-M11	1	IWLAN TERMINATION IMPEDANCE TI 795-1R	Siemens	SIE.6GK5795-1TR10-0AA6
=523TR01+CK.06-M11	1	IWLAN RCOAX N-CONNECT FEMALE ANTENNA ANT792-4DN	Siemens	SIE.6GK5792-4DN00-0AA6
=523TR01+CK.06-M11	1	SIMATIC NET, IWLAN N-CONNECT	Siemens	SIE.6XV1875-5CH10
=523TR01+CK.06-M11	1	RCOAX-CABLE	Siemens	SIE.6XV1875-2A235M
=523TR01+CK.06-M12	1	Power supply PS791-2AC	Siemens	SIE.6GK5791-2AC00-0AA0
=523TR01+CK.06-M12	1	IWLAN access point SCALANCE W786-2RR	Siemens	SIE.6GK5786-2BA60-6AA0
=523TR01+CK.06-M12	1	IWLAN TERMINATION IMPEDANCE TI 795-1R	Siemens	SIE.6GK5795-1TR10-0AA6
=523TR01+CK.06-M12	1	IWLAN RCOAX N-CONNECT FEMALE ANTENNA ANT792-4DN	Siemens	SIE.6GK5792-4DN00-0AA6
=523TR01+CK.06-M12	1	SIMATIC NET, IWLAN N-CONNECT	Siemens	SIE.6XV1875-5CH10

1.a

1.c

Date	20.10.2010	Tripper car 523 TR 01 Tonasa		Parts list : SIE.3SB3246-0AA21 - SIE.6XV1875-5CH10	20.230	= 523TR01
Ed.	Schmidt				28/04/2010	+ STKL
Appr	Dauterstedt				12345	Page 1.b of 1.c
Modification	Date	Name	Original	Replacement of	Replaced by	058



# Cable overview

F10\_001

Cable name	Source (from)	Target (to)	cable type	all conductors	Conductors used	Cross-section [mm <sup>2</sup> ]	Length [m]	function text	Graphical page of cable diagram
LT1PO1	+MC1.03-X01	+ER-LT1 PE	H07RN-F G	4	4	6mm <sup>2</sup>		Lighting transformer	=523TR01+CABLE/2
MC1PO1	+DS1-X	L1 L2 L3 +MC1.01-PE	12HRD11YH	4	4	50mm <sup>2</sup>		Supply voltage 380V AC	=523TR01+CABLE/3
MC1PO2	+MC1.03-X01	+ER-LT1 PE	H07RN-F G	5	5	6mm <sup>2</sup>		Lighting transformer	=523TR01+CABLE/4
MO1CO1	+MC1.20-X06	+MO1-B1 +MO1-B2	H07RN-F G	5	4	1mm <sup>2</sup>		Travel drive A-side	=523TR01+CABLE/5
MO1PO1	+MC1.20-X01	+MO1-M1	H07RN-F G	4	4	2,5mm <sup>2</sup>		Travel drive A-side	=523TR01+CABLE/6
MO2CO1	+MC1.20-X06	+MO2-B1 +MO2-B2	H07RN-F G	5	4	1mm <sup>2</sup>		Travel drive B-side	=523TR01+CABLE/7
MO2PO1	+MC1.20-X01	+MO2-M2	H07RN-F G	4	4	2,5mm <sup>2</sup>		Travel drive B-side	=523TR01+CABLE/8
W3	+MC1.03-X01	+CK.03-E10	H07RN-F G	3	2	2,5mm <sup>2</sup>		Walk way lights	=523TR01+CABLE/9
W4	+MC1.03-X01	+CK.03-E19	H07RN-F G	3	2	2,5mm <sup>2</sup>		=	=523TR01+CABLE/10
W5	+MC1.03-X01	+CK.03-S01	H07RN-F G	3	2	1,5mm <sup>2</sup>		Lighting local ON	=523TR01+CABLE/11
W6	+MC1.03-X01	+CK.03-S02	H07RN-F G	3	2	1,5mm <sup>2</sup>		=	=523TR01+CABLE/12
W7	+MC1.06-X03.1	+CK.06-MI1	H07RN-F G	3	3	2,5mm <sup>2</sup>		220V AC	=523TR01+CABLE/13
W8	+MC1.05-A40	+CK.06-MI1	Ethernet cable		1			=	=523TR01+CABLE/14
W9	+MC1.09-X03.1	+CK.09-S51	H07RN-F G	5	4	1,5mm <sup>2</sup>		Emergency stop switch 2	=523TR01+CABLE/15
W10	+MC1.09-X03.1	+CK.09-S52	H07RN-F G	5	4	1,5mm <sup>2</sup>		Emergency stop switch 3	=523TR01+CABLE/16
W11	+MC1.09-X03.1	+CK.09-S53	H07RN-F G	5	4	1,5mm <sup>2</sup>		Emergency stop switch 4	=523TR01+CABLE/17
W12	+MC1.09-X03.1	+CK.09-S54	H07RN-F G	5	4	1,5mm <sup>2</sup>		Emergency stop switch 5	=523TR01+CABLE/18
W13	+MC1.09-X03.1	+CK.09-B11	H07RN-F G	5	4	1,5mm <sup>2</sup>		Pull rope right	=523TR01+CABLE/19
W14	+MC1.09-X03.1	+CK.09-B21	H07RN-F G	5	4	1,5mm <sup>2</sup>		Pull rope left	=523TR01+CABLE/20
W15	+MC1.09-X03.1	+CK.09-S55	H07RN-F G	5	4	1,5mm <sup>2</sup>		Emergency stop 244BC07	=523TR01+CABLE/21
W16	+MC1.09-X03.1	+CK.09-S56	H07RN-F G	5	4	1,5mm <sup>2</sup>		=	=523TR01+CABLE/22
W17	+MC1.17-X03	+CK.17-B01	H07RN-F G	5	2	1,5mm <sup>2</sup>		Chute overfilled	=523TR01+CABLE/23
W18	+MC1.17-X03	+CK.17-B22	H07RN-F G	3	2	1,5mm <sup>2</sup>		Misalignment left	=523TR01+CABLE/24
W19	+MC1.17-X03	+CK.17-B12	H07RN-F G	3	2	1,5mm <sup>2</sup>		Misalignment right	=523TR01+CABLE/25
W25	+MC1.20-X03	+JB.20-X03	H07RN-F G	12	8	1,5mm <sup>2</sup>		Travel drive way end absolute right	=523TR01+CABLE/26
W26	+JB.20-X03	+CK.20-B11	H07RN-F G	7	5	1,5mm <sup>2</sup>		=	=523TR01+CABLE/27
W27	+MC1.20-X05	+CK.20-B31	RS_KA421		10				=523TR01+CABLE/28
W28	+JB.20-X03	+CK.20-B12	H07RN-F G	3	2	1,5mm <sup>2</sup>		Travel drive way end right	=523TR01+CABLE/29
W29	+JB.20-X03	+CK.20-B22	H07RN-F G	3	2	1,5mm <sup>2</sup>		Travel drive way end left	=523TR01+CABLE/30
W30	+JB.20-X03	+CK.20-B40	H07RN-F G	3	1	1,5mm <sup>2</sup>		=	=523TR01+CABLE/31
W34	+MC1.20-X06	+CK.20-B91	LiC(CY)	2x2x	3	0,5mm <sup>2</sup>			=523TR01+CABLE/32
W35	+MC1.20-X06	+CK.20-B92	LiC(CY)	2x2x	3	0,5mm <sup>2</sup>		Material detection forward	=523TR01+CABLE/33
W36	+MC1.20-X06	+CK.20-B93	LiC(CY)	2x2x	3	0,5mm <sup>2</sup>			=523TR01+CABLE/34
W37	+MC1.20-X06	+CK.20-B94	LiC(CY)	2x2x	3	0,5mm <sup>2</sup>		Frame detection forward	=523TR01+CABLE/35

+STKL/1.c

2

Date		20.10.2010		Tripper car 523 TR 01			Cable overview : LT1PO1 - W37	20.230		= 523TR01
Ed.		Schmidt		Tonasa				28/04/2010		+ CABLE
Appr		Dauterstedt						12345		Page 1 of 35
Modification	Date	Name	Original	Replacement of	Replaced by					960





# Cable diagram

F09\_001

Cable name	cable type		no. of conductors		cross-section	cable length		function text
MC1PO2	H07RN-F G		5		6mm <sup>2</sup>			Lighting transformer
function text	X-Ref	Target designation from	Connection point	conductor	Target designation to	Connection point	X-Ref	function text
Lighting transformer	=523TR01+MC1.03/1.6	=523TR01+MC1.03-X01	7		=523TR01+ER-LT1	2U1	=523TR01+MC1.03/1.6	Lighting transformer
=	=523TR01+MC1.03/1.6	=523TR01+MC1.03-X01	8		=523TR01+ER-LT1	2V1	=523TR01+MC1.03/1.6	
=	=523TR01+MC1.03/1.6	=523TR01+MC1.03-X01	9		=523TR01+ER-LT1	2W1	=523TR01+MC1.03/1.6	
=	=523TR01+MC1.03/1.6	=523TR01+MC1.03-X01	N		=523TR01+ER-LT1	N	=523TR01+MC1.03/1.6	
=	=523TR01+MC1.03/1.6	=523TR01+MC1.03-X01	PE		PE	11	=523TR01+MC1.03/1.6	





















# Cable diagram

F09\_001

Cable name W9		cable type H07RN-F G		no. of conductors 5		cross-section 1,5mm <sup>2</sup>		cable length		function text Emergency stop switch 2	
function text		X-Ref	Target designation from	Connection point	conductor	Target designation to	Connection point	X-Ref	function text		
Emergency stop switch 2		=523TR01+MC1.09/2.2	=523TR01+MC1.09-X03.1	3		=523TR01+CK.09-S51	21	=523TR01+MC1.09/2.2	Emergency stop switch 2		
=		=523TR01+MC1.09/2.2	=523TR01+MC1.09-X03.1	4		=523TR01+CK.09-S51	22	=523TR01+MC1.09/2.2			
		=523TR01+MC1.09/4.1	=523TR01+MC1.09-X03.1	23		=523TR01+CK.09-S51	31	=523TR01+MC1.09/4.1			
		=523TR01+MC1.09/4.1	=523TR01+MC1.09-X03.1	24		=523TR01+CK.09-S51	32	=523TR01+MC1.09/4.1			





# Cable diagram

F09\_001

Cable name W12	cable type H07RN-F G		no. of conductors 5		cross-section 1,5mm <sup>2</sup>	cable length		function text Emergency stop switch 5
function text	X-Ref	Target designation from	Connection point	conductor	Target designation to	Connection point	X-Ref	function text
Emergency stop switch 5	=523TR01+MC1.09/2.5	=523TR01+MC1.09-X03.1	9		=523TR01+CK.09-S54	21	=523TR01+MC1.09/2.5	Emergency stop switch 5
=	=523TR01+MC1.09/2.5	=523TR01+MC1.09-X03.1	10		=523TR01+CK.09-S54	22	=523TR01+MC1.09/2.5	
	=523TR01+MC1.09/4.4	=523TR01+MC1.09-X03.1	29		=523TR01+CK.09-S54	31	=523TR01+MC1.09/4.4	
	=523TR01+MC1.09/4.4	=523TR01+MC1.09-X03.1	30		=523TR01+CK.09-S54	32	=523TR01+MC1.09/4.4	











# Cable diagram

F09\_001

Cable name W18	cable type H07RN-F G		no. of conductors 3		cross-section 1,5mm <sup>2</sup>	cable length		function text Misalignment left
function text	X-Ref	Target designation from	Connection point	conductor	Target designation to	Connection point	X-Ref	function text
Misalignment left	=523TR01+MC1.17/1.4	=523TR01+MC1.17-X03	5		=523TR01+CK.17-B22	21	=523TR01+MC1.17/1.4	Misalignment left
=	=523TR01+MC1.17/1.4	=523TR01+MC1.17-X03	6		=523TR01+CK.17-B22	22	=523TR01+MC1.17/1.4	







# Cable diagram

F09\_001

Cable name W27	cable type RS_KA421		no. of conductors		cross-section	cable length		function text
function text	X-Ref	Target designation from	Connection point	conductor	Target designation to	Connection point	X-Ref	function text
	=523TR01+MC1.20/8.1	=523TR01+MC1.20-X05	6		=523TR01+CK.20-B31	2	=523TR01+MC1.20/8.1	
Travel drive position	=523TR01+MC1.20/8.1	=523TR01+MC1.20-X05	7		=523TR01+CK.20-B31	1	=523TR01+MC1.20/8.1	Travel drive position
=	=523TR01+MC1.20/8.2	=523TR01+MC1.20-X05	8		=523TR01+CK.20-B31	7	=523TR01+MC1.20/8.2	
=	=523TR01+MC1.20/8.2	=523TR01+MC1.20-X05	9		=523TR01+CK.20-B31	3	=523TR01+MC1.20/8.2	
=	=523TR01+MC1.20/8.3	=523TR01+MC1.20-X05	10		=523TR01+CK.20-B31	6	=523TR01+MC1.20/8.3	
=	=523TR01+MC1.20/8.3	=523TR01+MC1.20-X05	11		=523TR01+CK.20-B31	4	=523TR01+MC1.20/8.3	
=	=523TR01+MC1.20/8.3	=523TR01+MC1.20-X05	12		=523TR01+CK.20-B31	5	=523TR01+MC1.20/8.3	
=	=523TR01+MC1.20/8.4	=523TR01+MC1.20-X05	13		=523TR01+CK.20-B31	8	=523TR01+MC1.20/8.4	
=	=523TR01+MC1.20/8.4	=523TR01+MC1.20-X05	14		=523TR01+CK.20-B31	10	=523TR01+MC1.20/8.4	
=	=523TR01+MC1.20/8.4	=523TR01+MC1.20-X05	15		=523TR01+CK.20-B31	9	=523TR01+MC1.20/8.4	











# Cable diagram

F09\_001

Cable name W36	cable type LiC(CY)		no. of conductors 2x2x		cross-section 0,5mm²	cable length		function text
	function text	X-Ref	Target designation from	Connection point	conductor	Target designation to	Connection point	X-Ref
	=523TR01+MC1.20/11.1	=523TR01+MC1.20-X06	15		=523TR01+CK.20-B93	YE	=523TR01+MC1.20/11.1	
	=523TR01+MC1.20/11.2	=523TR01+MC1.20-X06	16		=523TR01+CK.20-B93	RD	=523TR01+MC1.20/11.2	
	=523TR01+MC1.20/11.2				=523TR01+CK.20-B93	BK	=523TR01+MC1.20/11.2	
	=523TR01+MC1.20/11.2	=523TR01+MC1.20-X06	17		=523TR01+CK.20-B93	BK	=523TR01+MC1.20/11.2	

# Cable diagram

F09\_001

Cable name W37	cable type LiC(CY)		no. of conductors 2x2x		cross-section 0,5mm <sup>2</sup>	cable length		function text Frame detection forward	
	function text	X-Ref	Target designation from	Connection point	conductor	Target designation to	Connection point	X-Ref	function text
Frame detection forward	=523TR01+MC1.20/11.6	=523TR01+MC1.20-X06	18		=523TR01+CK.20-B94	YE	=523TR01+MC1.20/11.6		
=	=523TR01+MC1.20/11.6	=523TR01+MC1.20-X06	19		=523TR01+CK.20-B94	RD	=523TR01+MC1.20/11.6		
=	=523TR01+MC1.20/11.6				=523TR01+CK.20-B94	BK	=523TR01+MC1.20/11.6		
=	=523TR01+MC1.20/11.6	=523TR01+MC1.20-X06	20		=523TR01+CK.20-B94	BK	=523TR01+MC1.20/11.6		

Modification	Date	Name	Original	Replacement of	Replaced by		Cable diagram W37	20.230	= 523TR01
								28/04/2010	+ CABLE
								12345	Page 35 of 35















# Terminal diagram

F13\_001

function text	Cable name	Cable type	Target designation	Connection point	terminal	Jumper	Target designation	Connection point	Cable name	Cable type	Target designation	Connection point	Page / column
					1	•	-Q1	2					/1.1
					2	•	-Q1	4					/1.1
					3	•	-Q1	6					/1.1
Lighting transformer			+ER-LT1	1U1	4	•	-Q2	2					/1.4
=			+ER-LT1	1V1	5	•	-Q2	4					/1.4
=			+ER-LT1	1W1	6	•	-Q2	6					/1.4
=			+ER-LT1	2U1	7	•	-Q3	1					/1.6
=			+ER-LT1	2V1	8	•	-Q3	3					/1.6
=			+ER-LT1	2W1	9	•	-Q3	5					/1.6
Walk way lights			+CK.03-E10	L	10	•	-K1	2					/2.0
=			+CK.03-E19	L	11	•	-K1	4					/2.1
Lighting local ON			+CK.03-S01	13	12	┌─┐ └─┘	-F3	2					/2.2
=			+CK.03-S01	14	13								
=			+CK.03-S02	13	14	┌─┐ └─┘							/2.3
=			+CK.03-S02	14	15			-K1	A1				
=					16	•	-F4	2					/2.6
=					17	•	-F5	2					/2.6
Lighting transformer			+ER-LT1	N	N	┌─┐ └─┘							/1.6
Walk way lights			+CK.03-E10	N	N								
=			+CK.03-E19	N	N	┌─┐ └─┘	-K1	A2					/2.2
Lighting local ON					N			-K1	A2				
=					N	┌─┐ └─┘	+.04-X01	N					/2.6
					PE			PE					
							-X01	PE					
Lighting transformer			PE	9	PE	•	-X01	PE					/1.4
							-X01	PE					
Lighting transformer			PE	11	PE	•	-X01	PE					/1.6
							PE						
Walk way lights					PE	•	PE						/2.1
							-X01	PE					
Walk way lights					PE	•	-X01	PE					/2.2
							-X01	PE					
Lighting local ON					PE	•	-X01	PE					/2.3
							-X01	PE					
Lighting local ON					PE	•	-X01	PE					/2.4

Date	20.10.2010	Tripper car 523 TR 01		Terminal diagram =523TR01+MC1.03-X01	20.230	= 523TR01
Ed.	Schmidt	Tonasa			28/04/2010	+ Clamps
Appr	Dauterstedt				12345	Page 8 of 20
Modification	Date	Name	Original	Replacement of	Replaced by	104

# Terminal diagram

F13\_001

function text	Cable name	Cable name	Cable type	Target designation	Connection point	terminal	Jumper	Target designation	Connection point	Cable type	Cable name	Cable name	Cable type	Page / column
Lighting local ON						PE	*	-X01	PE					/2.6
								-X01	PE					
Lighting local ON						PE	*	-X01	PE					/2.7
								PE						

# Terminal diagram

F13\_001

function text	Cable name	Cable name	Strip				Cable name	Cable name	Page / column
			=523TR01+MC1.04-X01	Target designation	Connection point	terminal			
			-F1	2	1	•			/2.1
			-S01	1	2	•	-E01	x1	/2.5
			-F3	2	3	•	-XU1	1	/2.7
			+ .03-X01	N	N	┌			/2.1
			-E01	x2	N	└			/2.5
			-XU1	2	N	└			/2.7
			PE		PE	•			/2.1
			-X01	PE					
			-E01	PE	PE	•	-X01	PE	/2.5
							-X01	PE	
			-X01	PE	PE	•	-XU1	PE	/2.7
			PE						

8.a

10



# Terminal diagram

F13\_001

function text	Cable name	Cable type	Strip = 523TR01+MC1.09-X03.1				Cable name	Cable type	Connection point	Page / column
			Target designation	Connection point	terminal	Jumper				
			-S50	21	1	•	-K01	Y11	/2.1	
			-S50	22	2	•			/2.1	
Emergency stop switch 2			+CK.09-S51	21	3	•			/2.2	
=			+CK.09-S51	22	4	•			/2.2	
Emergency stop switch 3			+CK.09-S52	21	5	•			/2.3	
=			+CK.09-S52	22	6	•			/2.3	
Emergency stop switch 4			+CK.09-S53	21	7	•			/2.4	
=			+CK.09-S53	22	8	•			/2.4	
Emergency stop switch 5			+CK.09-S54	21	9	•			/2.5	
=			+CK.09-S54	22	10	•			/2.5	
Pull rope right			+CK.09-B11	21	11	•			/2.6	
=			+CK.09-B11	22	12	•			/2.7	
Pull rope left			+CK.09-B21	21	13	•			/2.8	
Pull rope left			+CK.09-B21	22	14	•			/2.8	
=					15	•			/2.9	
=					16	•			/2.9	
Emergency stop 244BC07			+CK.09-S55	21	17	•			/3.2	
=			+CK.09-S55	22	18	•			/3.2	
=			+CK.09-S56	21	19	•			/3.3	
=			+CK.09-S56	22	20	•			/3.3	
=					21	•			/3.4	
=					22	•	-K01	Y12	/3.4	
			+CK.09-S51	31	23	•			/4.1	
			+CK.09-S51	32	24	•	-K61	A1	/4.1	
			+CK.09-S52	31	25	•			/4.2	
			+CK.09-S52	32	26	•	-K62	A1	/4.2	
			+CK.09-S53	31	27	•			/4.3	
			+CK.09-S53	32	28	•	-K63	A1	/4.3	
			+CK.09-S54	31	29	•			/4.4	
			+CK.09-S54	32	30	•	-K64	A1	/4.4	
			+CK.09-B11	31	31	•			/4.5	
			+CK.09-B11	32	32	•	-K65	A1	/4.5	
			+CK.09-B21	31	33	•			/4.6	
			+CK.09-B21	32	34	•	-K66	A1	/4.6	
			+CK.09-S55	31	35	•			/4.7	

Date	20.10.2010	Tripper car 523 TR 01		Terminal diagram =523TR01+MC1.09-X03.1	20.230	= 523TR01
Ed.	Schmidt				28/04/2010	+ Clamps
Appr	Dauterstedt				12345	Page 11 of 20
Modification	Date	Name	Original	Replacement of	Replaced by	108

# Terminal diagram

F13\_001

function text	Cable name		Strip = 523TR01+MC1.09-X03.1				Cable name		Page / column
	W16	W15	Connection point	terminal	Jumper	Target designation	Connection point	cable type	
			+CK.09-S55	32	36	•	-K67	A1	/4.7
			+CK.09-S56	31	37	•		A1	/4.9
			+CK.09-S56	32	38	•	-K68		/4.9
Emergency stop switch 2					PE	•	PE		/2.2
							-X03.1	PE	
Emergency stop switch 3					PE	•	-X03.1	PE	/2.3
							-X03.1	PE	
Emergency stop switch 4					PE	•	-X03.1	PE	/2.4
							-X03.1	PE	
Emergency stop switch 5					PE	•	-X03.1	PE	/2.6
							-X03.1	PE	
Pull rope right					PE	•	-X03.1	PE	/2.7
							-X03.1	PE	
Pull rope left					PE	•	-X03.1	PE	/2.8
							-X03.1	PE	
Pull rope left					PE	•	-X03.1	PE	/2.9
							PE		
Emergency stop 244BC07					PE	•	PE		/3.2
							-X03.1	PE	
Emergency stop 244BC07					PE	•	-X03.1	PE	/3.3
							-X03.1	PE	
Emergency stop 244BC07					PE	•	-X03.1	PE	/3.4
							PE		

# Terminal diagram

F13\_001

function text	Cable name	cable type	Strip =523TR01+MC1.09-X05					Cable name	cable type	Page / column
			Target designation	Connection point	terminal	Jumper	Target designation			
Emergency stop pushbutton 1 panel door not pushed			-S50	31	1	•	-K01	23	/5.1	
								11		
Emergency stop pushbutton 1 panel door not pushed			+05-A03	5	2	•	-S50	32	/5.1	
Manual mode selected			+05-A05	1	3	•	-S1	12	/6.1	
Automatic mode selected			+05-A05	5	4	•	-S1	14	/6.2	
Control ON			+05-A05	2	5	•	-S2	14	/6.3	
Control OFF			+05-A05	6	6	•	-S3	12	/6.4	
Lamp test			+05-A06	1	7	•	-S4	14	/6.5	
=			-K36	A1	8	•	-S5	14	/6.6	
Signallamp Control ON			-S2	x1	9	•	+05-A13	2	/7.2	
Signallamp Control OFF			-S3	x1	10	•	+05-A13	6	/7.3	
Signallamp Automatic mode ON			-H2	x1	11	•	+05-A14	1	/7.4	
Centralized fault indication			-H1	x1	12	•	+05-A14	5	/7.5	
Signallamp Reset			-S5	x1	13	•	+05-A14	2	/7.6	

	Date	20.10.2010	Tripper car 523 TR 01			Terminal diagram =523TR01+MC1.09-X05	20.230	= 523TR01
	Ed.	Schmidt	Tonasa				28/04/2010	+ Clamps
Modification	Date	Name	Original	Replacement of			Replaced by	12345

# Terminal diagram

F13\_001

function text	Cable name	Cable type	Strip =523TR01+MC1.17-X03				Cable name	Cable type	Page / column
			Target designation	Connection point	terminal	Jumper			
Chute overfiled	W17	H07RN-F-G	+CK.17-B01	1	1		+02-F12	2	/1.2
=			+CK.17-B01	2	2			+02-X03	2
Chute overfiled	W18	H07RN-F-G			3		-K61	A2	/1.2
=			-K61	A1	4				
Misalignment left	W19	H07RN-F-G	+CK.17-B22	21	5				/1.4
=			-K62	A1	6			+CK.17-B22	22
Misalignment right			+CK.17-B12	21	7				/1.6
=			-K63	A1	8			+CK.17-B12	22
Chute overfiled			PE		PE				/1.2

# Terminal diagram

F13\_001

function text	Cable name		Strip =523TR01+MC1.20-X01				Cable name		Page / column
	M01P01	M02P01	Connection point	terminal	Jumper	Target designation	Connection point	cable type	
Travel drive A-side			+M01-M1	U1	1	•	-Q11	2	/1.1
=			+M01-M1	V1	2	•	-Q11	4	/1.1
=			+M01-M1	W1	3	•	-Q11	6	/1.1
Travel drive B-side			+M02-M2	U1	4	•	-Q12	2	/1.4
=			+M02-M2	V1	5	•	-Q12	4	/1.5
=			+M02-M2	W1	6	•	-Q12	6	/1.5
Travel drive A-side			+M01-M1	PE	PE	•	PE	PE	/1.1
Travel drive B-side			+M02-M2	PE	PE	•	-X06	PE	/1.5
							-X06	PE	

# Terminal diagram

F13\_001

function text	Cable name		Strip =523TR01+MC1.20-X03				Cable name		Page / column
	WZ5	H07RN-F-G	Target designation	Connection point	terminal	Jumper	Target designation	Connection point	
			+JB.20-X03	1	1	•	-K01	14	/2.7
							-K33	11	
			-Q1	A1	2	•	+JB.20-X03	2	/2.7
			+ER-R1	T1	3	•	-G1	21	/3.4
			+ER-R1	T2	4	•	-K58	A1	/3.4
Travel drive way end absolute right			+JB.20-X03	3	5	•			/9.0
=			-K61	A1	6	•	+JB.20-X03	4	/9.0
Travel drive way end absolute left					7	•			/9.1
=			-K62	A1	8	•	+JB.20-X03	5	/9.1
Travel drive way end right					9	•			/9.3
=			-K63	A1	10	•	+JB.20-X03	7	/9.3
Travel drive way end left					11	•			/9.4
=			-K64	A1	12	•	+JB.20-X03	9	/9.4
=					13	•			/9.5
=			-K65	A1	14	•	+JB.20-X03	11	/9.5

# Terminal diagram

F13\_001

function text	Cable name	cable type	Strip =523TR01+MC1.20-X05				Cable name	Cable type	Page / column
			Target designation	Connection point	terminal	Jumper			
Travel drive OFF			+05-A08	1	1	•	-S30	12	/4.1
Travel drive right ON			+05-A08	5	2	•	-S31	14	/4.2
Travel drive left ON			+05-A08	2	3	•	-S32	14	/4.3
Signallamp Travel drive right ON			-S31	x1	4	•	+05-A15	1	/4.5
Signallamp Travel drive left ON			-S32	x1	5	•	+05-A15	5	/4.6
			+05-A21	3	6	•	+CK.20-B31	2	/8.1
Travel drive position			+05-A21	2	7	•	+CK.20-B31	1	/8.1
=			+05-A21	8	8	•	+CK.20-B31	7	/8.2
=			+05-A21	4	9	•	+CK.20-B31	3	/8.2
=			+05-A21	5	10	•	+CK.20-B31	6	/8.3
=			+05-A21	1	11	•	+CK.20-B31	4	/8.3
=			+05-A16	5	12	•	+CK.20-B31	5	/8.3
=					13	•	+CK.20-B31	8	/8.4
=					14	•	+CK.20-B31	10	/8.4
=					15	•	+CK.20-B31	9	/8.4
Nulljustage Resatron			-K52	21	16	•			/8.5

# Terminal diagram

F13\_001

function text	Cable name		Strip =523TR01+MC1.20-X06				Cable name		Page / column
	MO1C01	MO2C01	Target designation	Connection point	terminal	Jumper	Target designation	Connection point	
Travel drive A-side			+MO1-B1	x1	1	┌ ├ └			/1.2
=			+MO1-B1	x2	2		-F31	1T1	/1.2
=			+MO1-B2	x1	3		-F31	T2	/1.3
=			+MO1-B2	x2	4		-F31	2T1	/1.3
Travel drive B-side			+MO2-B1	x1	5	┌ ├ └			/1.6
=			+MO2-B1	x2	6		-F32	1T1	/1.6
=			+MO2-B2	x1	7		-F32	T2	/1.7
=			+MO2-B2	x2	8		-F32	2T1	/1.7
			+CK.20-B91	YE	9	•	-A01	9	/10.1
			+CK.20-B91	RD	10	•	-A01	11	/10.2
			+CK.20-B91	BK	11	•	-A01	10	/10.2
Material detection forward			+CK.20-B92	YE	12	•	-A02	9	/10.6
=			+CK.20-B92	RD	13	•	-A02	11	/10.6
=			+CK.20-B92	BK	14	•	-A02	10	/10.6
			+CK.20-B93	YE	15	•	-A03	9	/11.1
			+CK.20-B93	RD	16	•	-A03	11	/11.2
			+CK.20-B93	BK	17	•	-A03	10	/11.2
Frame detection forward			+CK.20-B94	YE	18	•	-A04	9	/11.6
=			+CK.20-B94	RD	19	•	-A04	11	/11.6
=			+CK.20-B94	BK	20	•	-A04	10	/11.6
Travel drive A-side						•	-X01	PE	/1.2
						•	-X06	PE	
Travel drive A-side						•	-X06	PE	/1.3
						•	-X01	PE	
Travel drive B-side						•	-X01	PE	/1.6
						•	-X06	PE	
Travel drive B-side						•	-X06	PE	/1.7
						•	PE		



# Terminal diagram

F13\_001

function text	Cable name	Cable type	Strip =523TR01+JB.20-X03				Cable name	Cable type	Page / column
			Target designation	Connection point	terminal	Jumper			
	W26	H07RN-F-G	+CK.20-B11	21	1	•	+MCI.20-X03	1	+MCI.20/2.7
	W25	H07RN-F-G	+MCI.20-X03	2	2	•	+CK.20-B11	42	+MCI.20/2.7
Travel drive way end absolute right			+CK.20-B11	13	3	•	+MCI.20-X03	5	+MCI.20/9.0
=			+MCI.20-X03	6	4	•	+CK.20-B11	14	+MCI.20/9.0
Travel drive way end absolute left			+MCI.20-X03	8	5	•	+CK.20-B11	34	+MCI.20/9.1
Travel drive way end right					6	•			+MCI.20/9.3
=			+MCI.20-X03	10	7	•			+MCI.20/9.3
Travel drive way end left					8	•			+MCI.20/9.4
=			+MCI.20-X03	12	9	•			+MCI.20/9.4
=			+CK.20-B40	3	10	•			+MCI.20/9.5
=			+MCI.20-X03	14	11	•	+CK.20-B40	4	+MCI.20/9.5

